

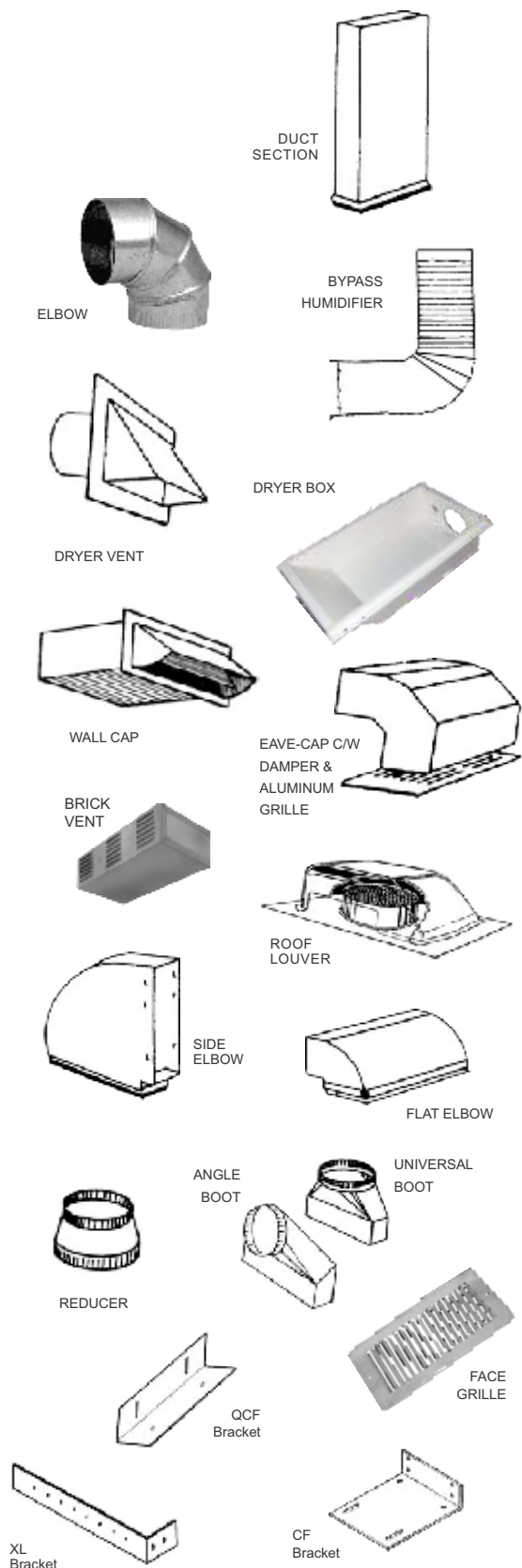

FAN & RANGE HOOD ACCESSORIES



	SIZE	PART NO.	SHIPPING WT. (KG)
DUCT SECTION 3 1/4" x 10" x Length	1'	6000	0.68
	2'	6001	1.36
	3'	6002	2.64
	4'	6003	2.72
	5'	6004	3.41
ELBOW - 28 Ga.	4" dia.		0.09
	5" dia.		0.14
	6" dia.		0.18
	7" dia.		0.23
BYPASS HUMIDIFIER KIT BHK100	6" dia.	6007	0.54
DRYER VENT, ALUMINUM	3" dia.		0.14
	4" dia.		0.14
	5" dia.		0.16
DRYER BOX (RDB-100)		6008	
WALL CAP	3 1/4" x 10"	6225	
EAVE CAP C/W DAMPER & GRILLE	3 1/4" x 10"	6005	1.36
GRILLE ONLY (ALUMINUM)	3 1/4" x 10"	6006	0.50
BRICK VENT		4000	
ROOF LOUVER	8"		
	10"		
ROOF LOUVER PAINTED	8"		0.23
	10"		0.68
FLAT ELBOW	3 1/4" x 10"		0.05
SIDE ELBOW	3 1/4" x 10"		0.09
REDUCERS/INCREASERS (HEAVY GAUGE)	3" - 4"		0.14
	4" - 5"		0.18
	5" - 6"		0.27
	6" - 7"		0.09
	7" - 8"		0.14
UNIVERSAL BOOT 3 1/4" X 10"	4" dia.		0.18
	5" dia.		0.23
	6" dia.		
	7" dia.		1.82
FACE GRILLE	4" x 10"		0.45
BRACKET FOR BES FANS			0.45
XL BRACKET			0.45
CF BRACKET			
QCF BRACKET			