

ULTRA SONE "TB" SERIES

Models QCF-200, QCF-300, QCF-400, QCF-500
CEILING OR IN-LINE TWIN BLOWER FANS

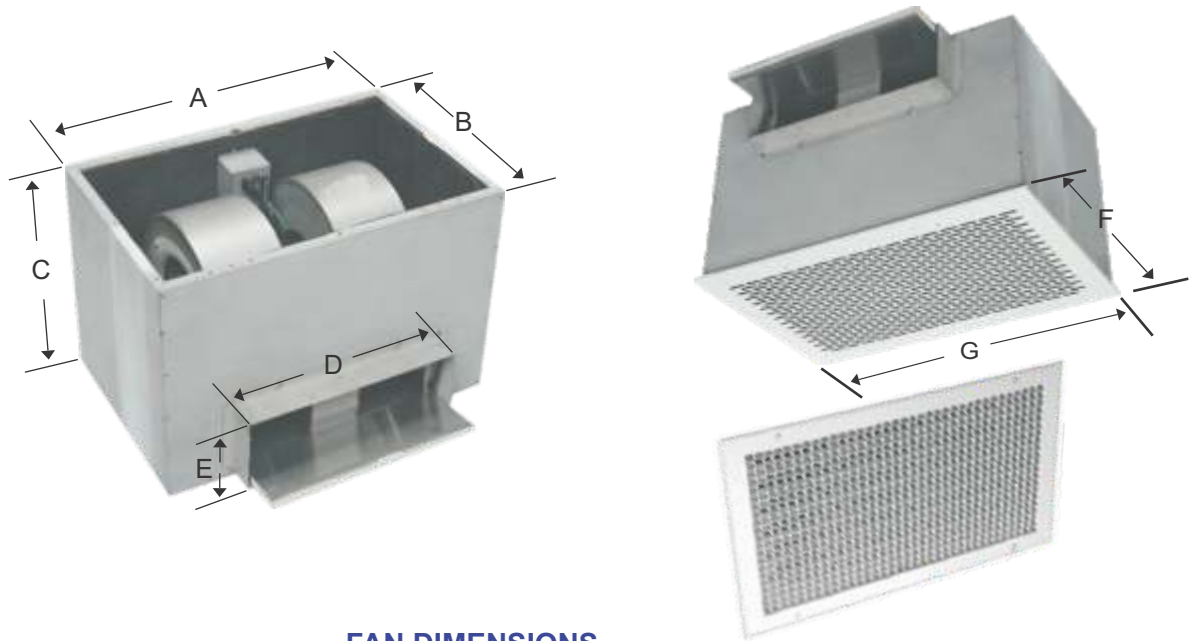

FAN DIMENSIONS

MODEL	A	B	C	D	E	F	G
QCF200	18	10	10	12	4	11	19
QCF300	18	10	10	12	4	11	19
QCF400	19	12	12	12	4	13	20
QCF500	24	14	14	18	5	15.5	25.5

STANDARD:

- White Perforated Steel Grille
- Continuous Duty Life Time Lubricated Motor with Thermal Protection
- Plug Type Disconnect
- Galvanized Metal Forward Curved Blower Wheels
- Universal Mounting Brackets
- Insulated Cabinet
- Neoprene Vibration Isolator
- Aluminum Backdraft Damper

OPTIONAL:

- White Aluminum Egg Crate Grille
- Speed Controller
- Inline Adapter Kit (call factory)
- Built In Fire Radiation Damper (see FF series)

QCF200, QCF300 FAN DATA

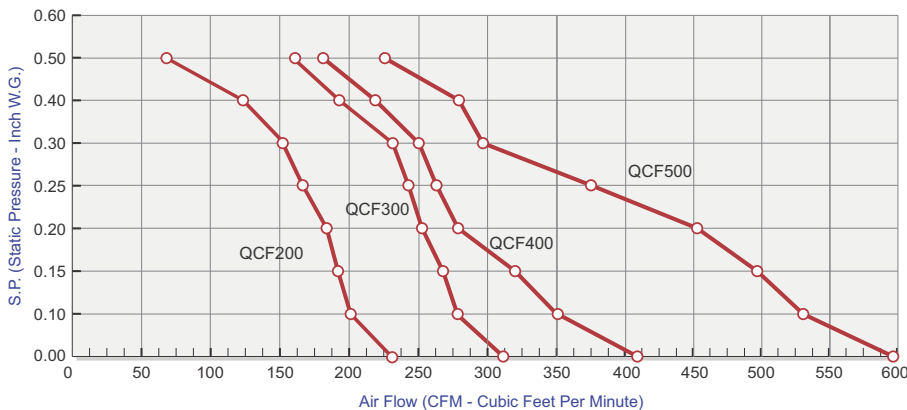

TYPICAL IN-LINE INSTALLATION

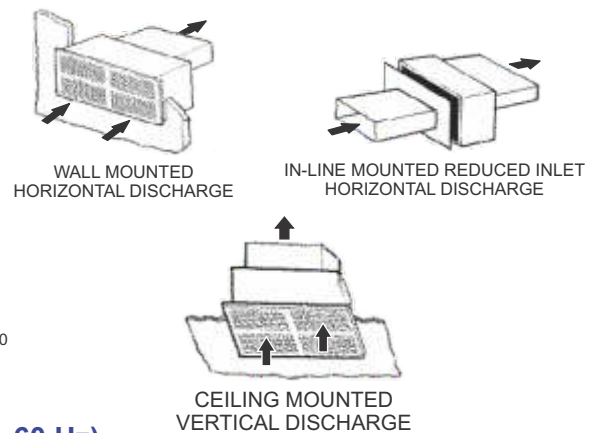

ULTRA SONE "TB" SERIES PERFORMANCE CHART (120V AC , 60 Hz)

MODEL	RPM	AMPS	WATTS	S.P.	0.00	0.10	0.15	0.20	0.25	0.30	0.40	0.50	SONES
QCF200	1350	0.76	91.2	CFM	230	204	192	181	166	152	122	67	3.0
QCF300	1200	1.25	150		310	281	266	252	241	230	191	158	4.0
QCF400	1080	1.60	192		411	350	315	280	265	250	215	180	4.0
QCF500	1050	4.20	504		594	535	495	455	375	292	280	225	4.0

ULTRA SONE "TB" SERIES

Models QCF-600, QCF-800, QCF-1000, QCF-1300, QCF-1600 CEILING OR IN-LINE TWIN BLOWER FANS

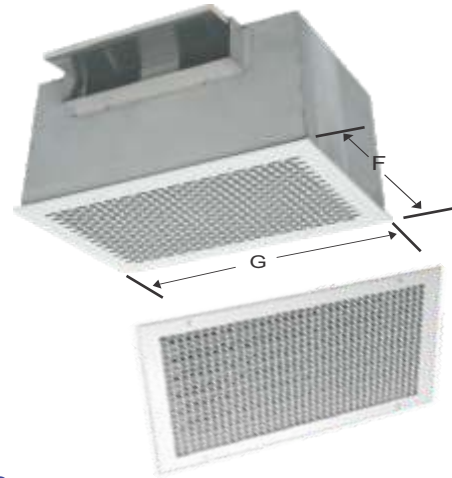
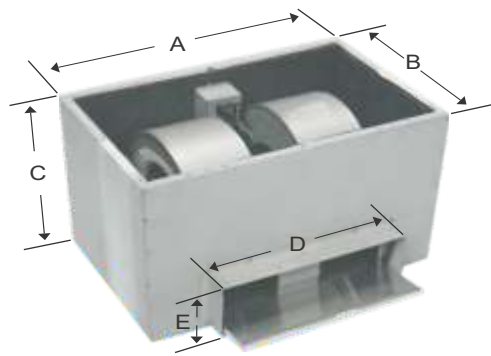

FAN DIMENSIONS

MODEL	A	B	C	D	E	F	G
QCF600	24	14	14	18	5	15.5	25.5
QCF800	24	14	14	18	5	15.5	25.5
QCF1000	32	14	14	24	6.5	15	33
QCF1300	38	14	14	28.5	6.5	15	39
QCF1600	38	14	14	28.5	6.5	15	39

STANDARD:

- White Perforated Steel Grille
- Continuous Duty Life Time Lubricated Motor with Thermal Protection
- Plug Type Disconnect
- Galvanized Metal Forward Curved Blower Wheels
- Universal Mounting Brackets
- Insulated Cabinet
- Neoprene Vibration Isolator
- Aluminum Backdraft Damper

OPTIONAL:

- White Aluminum Egg Crate Grille
- Speed Controller
- Inline Adapter Kit (call factory)
- Built In Fire Radiation Damper (see FF series)

QCF600, QCF800 FAN DATA

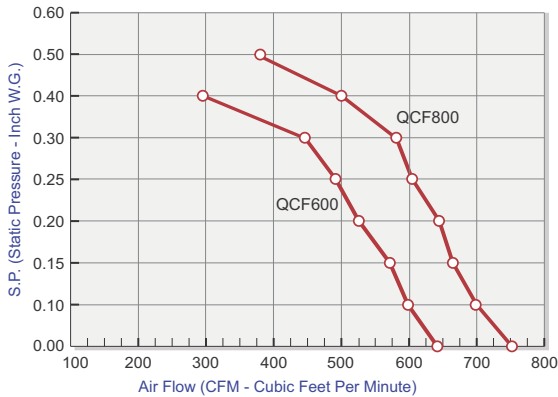

QCF1000, QCF1300, QCF1600 FAN DATA

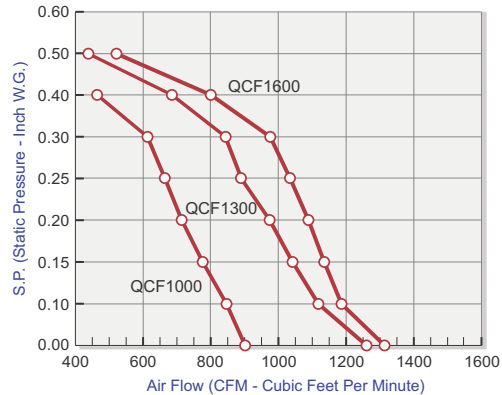

ULTRA SONE "TB" SERIES PERFORMANCE CHART (120V AC , 60 Hz)

MODEL	RPM	AMPS	WATTS	S.P. SOUND	S.P.							
					0.00	0.10	0.15	0.20	0.25	0.30	0.40	0.50
QCF600	1050	4.2	159	CFM	642	596	570	525	485	440	290	-
				SONES	7.1	6.4	6.3	6.2	6.1	6.0	5.8	-
QCF800	1050	5.2	185	CFM	755	693	668	640	610	580	500	380
				SONES	6.6	6.3	6.1	6.0	5.9	5.7	5.5	5.2
QCF1000	825	3.2	250	CFM	928	843	770	718	660	618	460	-
				SONES	5.3	5.1	5.1	5.0	4.9	4.8	4.6	-
QCF1300	825	3.2	293	CFM	1265	1130	1040	970	890	845	685	430
				SONES	8.8	7.5	7.5	7.5	5.9	6.0	5.8	5.5
QCF1600	825	3.2	309	CFM	1325	1200	1140	1080	1035	980	800	520
				SONES	9.4	6.9	6.6	6.3	6.0	5.3	5.0	4.7

Performance certified is for installation type B: free inlet, Ducted outlet. Performance ratings include the effects of an inlet grille and backdraft damper. Speed (rpm) shown is nominal. Performance is based on actual speed test. The sound ratings shown are loudness values in spherical fan sones at 5 ft (1.5m) in a spherical free field calculated per Annex B of AMCA 311. Values shown are for installation type B: free inlet spherical fan sone levels.