



DELUXE SERIES



Models:

SAS-80DC3/SAS-80DC3H/SAS-80DC3HM (Constant Flow Fan)

- Very quiet two speeds DC motor fan for ceiling or wall mount application.
- Continuous run-on low speed (Adjustable 0, 30CFM - Max CFM).
- Provide constant flow on all three speeds.
- ETL evaluated and confirm to UL and CUL safety standards.
- HVI and ENERGY STAR certified.
- Made of rugged 26 GA galvanized steel.
- Detachable 4-inch polymeric collar which includes a light weight built in back draft damper.
- Housing size: $10\frac{1}{4}'' \times 10\frac{1}{4}'' \times 3\frac{3}{8}''$
- Total enclosed brush less DC motor designed to operate continuously.
- Power rating of 120 VAC/1/60 Hz.
- Comes with a built-in overload disconnect for safety and longer motor life.
- The grille is low profile that has elegance and still able to maintain its simplicity.
- Grille dimension: $13'' \times 13\frac{3}{4}''$
- Built-in toggle switch for high speeds (50CFM/80CFM/100CFM) selection.
- Permanently lubricated motor designed for continuous operation.
- Model SAS-80DC3H comes with built-in humidity sensor.
- Model SAS-80DC3HM comes with built-in humidity and motion sensor.

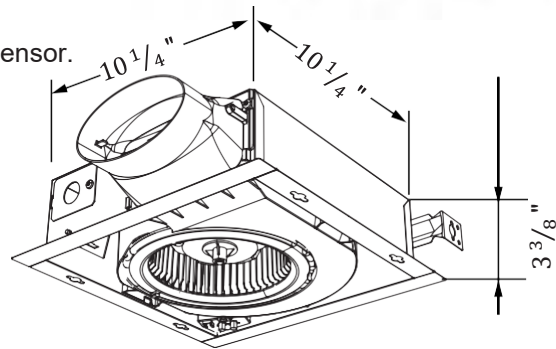
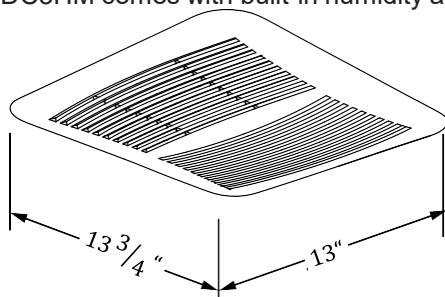
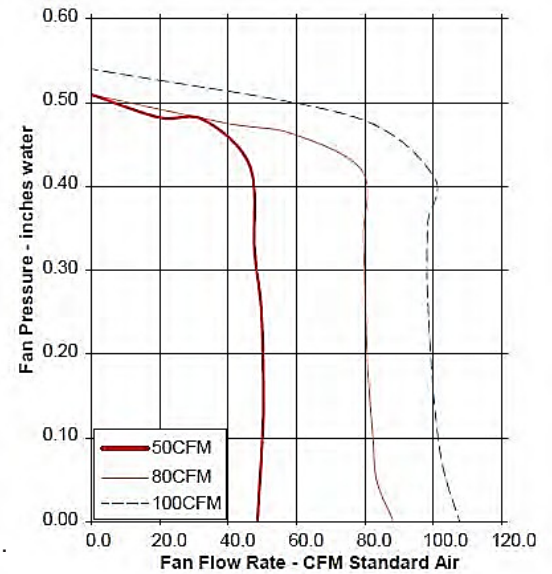

MODEL		50 CFM		80 CFM		100 CFM	
Static Pressure in inches W.G.		0.1	0.25	0.1	0.25	0.1	0.25
Air Volume (CFM)		50	50	80	80	100	100
Noise (Sones)		0.6	N/A	1.0	N/A	1.2	N/A
Fan Watts	12 W	Power Rating (V/ Hz)		120 V/ 60 Hz			