

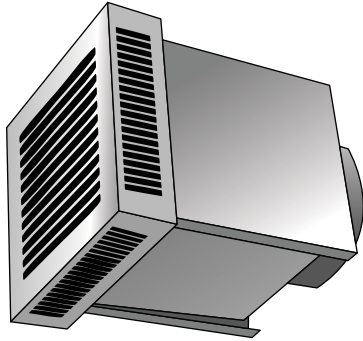

## ACCESSORIES: Super Quiet Wall Boxes

March, 2019



**SINGLE WALL BOX:**  
Model: EB1-8

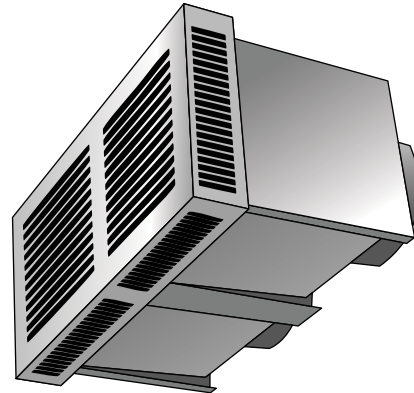

**DOUBLE WALL BOX:**  
Model: EB2-8

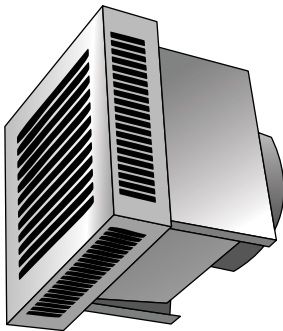

**JUNIOR WALL BOX:**  
Model: EBJ-8

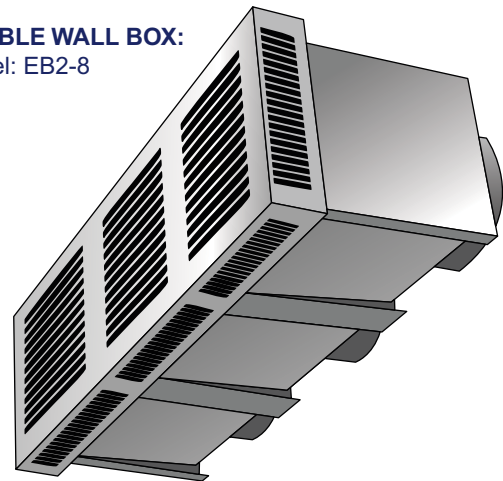

**TRIPLE WALL BOX:**  
Model: EB3-8

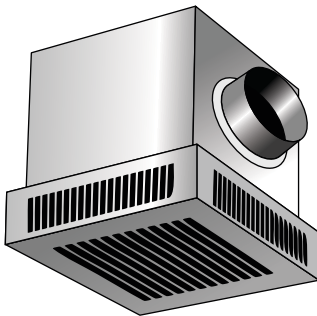

**SOFFIT WALL BOX:**  
Model: EBS-8

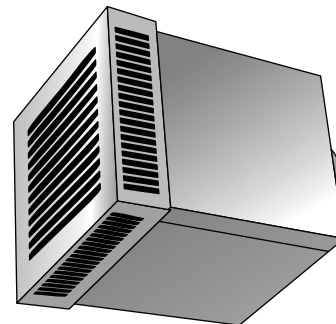

**INSULATED WALL BOX:**  
Model: EB1-I-8  
(add suffix "I" to the model number for insulation)  
1/2" Styro Foam insulation available for all models

**Reversomatic Manufacturing Ltd.**

790 Rowntree Dairy Road, Woodbridge, ON Canada L4L 5V3 • Tel: 905-851-6701 • Fax: 905-851-8376  
www.reversomatic.com • info@reversomatic.com

# ACCESSORIES: Super Quiet Wall Boxes

## SINGLE WALL BOX: Model: EB1-8

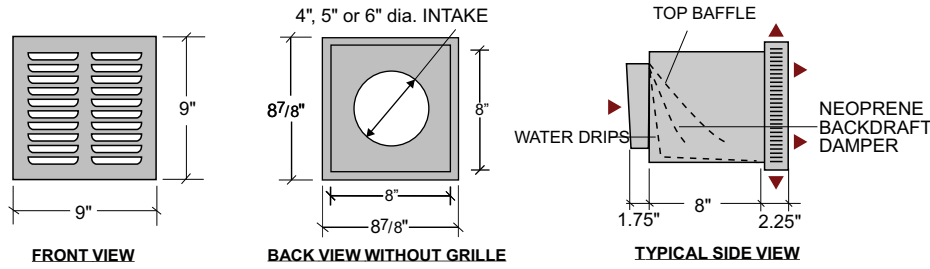

## DOUBLE WALL BOX: Model: EB2-8

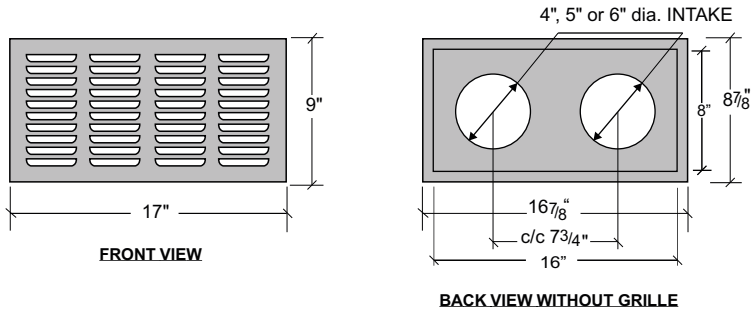

## TRIPLE WALL BOX: Model: EB3-8

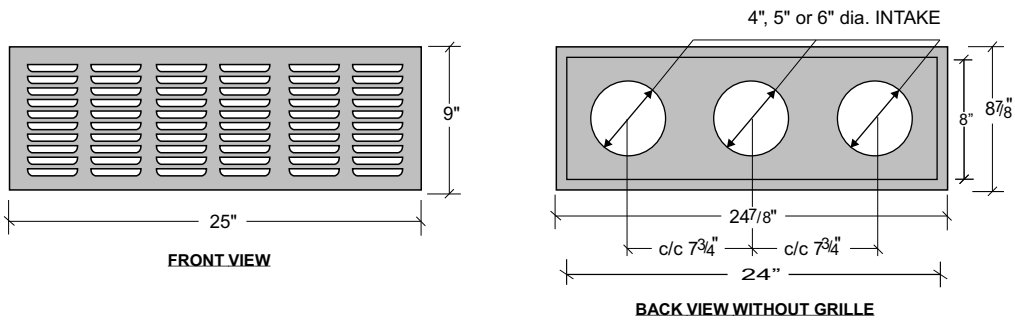

## SOFFIT WALL BOX: Model: EBS-8

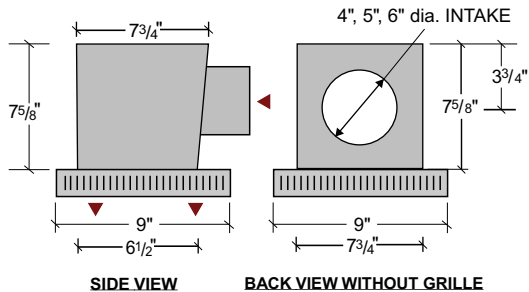

## JUNIOR WALL BOX

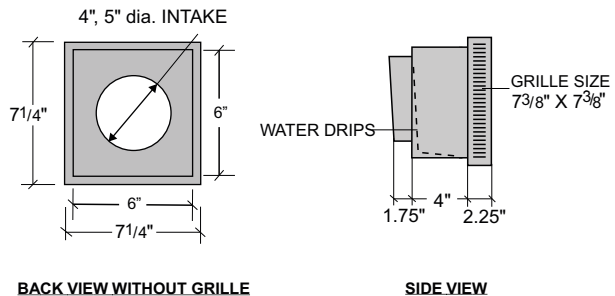

Contractor:		SUPER QUIET WALL BOXES		
Architect:	Job:	Data	Supersedes	Drawing NO.
Engineer:	Date Submitted:	3/15/2019		

### Reversomatic Manufacturing Ltd.

790 Rowntree Dairy Road, Woodbridge, ON Canada L4L 5V3 • Tel: 905-851-6701 • Fax: 905-851-8376  
 www.reversomatic.com • info@reversomatic.com