

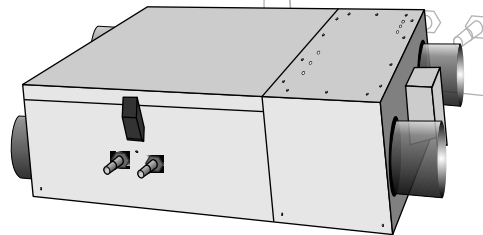

REVERSOMATIC
MANUFACTURING LIMITED

HRV / ERV INSTALLATION AND OPERATING INSTRUCTIONS



Deluxe ECM Series

model:
RHRV-D100P ES (ECM)
Polypropylene Core
RERV-D100 ES (ECM)
Enthalpy Core

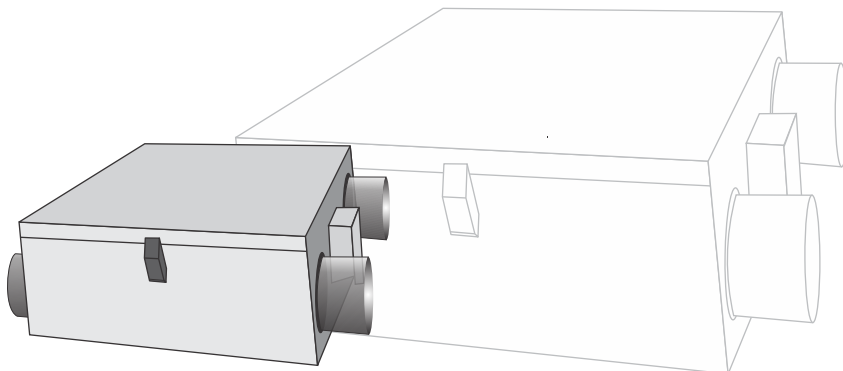

Superior ECM Series

model:
RHRV-S100P (ECM)
Polypropylene Core
RERV-S100 (ECM)
Enthalpy Core

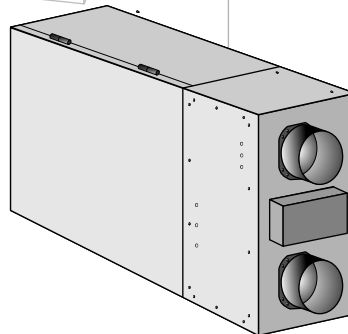

Maxum ECM Series

model:
RHRV-S200P (ECM)
Polypropylene Core
RERV-S200ES (ECM)
Enthalpy Core

790 Rowntree Dairy Road,
Woodbridge, ON Canada L4L 5V3
t: 905.851.6701
f: 905-851.8376
e: info@reversomatic.com

Toll Free: 1.800.810.3473 (Canada)
1.800.499.5073 (U.S.A.)

www.reversomatic.com



IMPORTANT SAFETY INSTRUCTIONS

READ AND SAVE THESE INSTRUCTIONS

⚠ WARNING ⚠

TO REDUCE THE RISK OF FIRE, ELECTRIC SHOCK OR INJURY, OBSERVE THE FOLLOWING:

1. Read all the instructions carefully before installation, operation or maintenance of the unit. Failure to comply with instructions could result in personal injury and/or property damage.
2. Installation of the unit and the corresponding electrical wiring must be done by a qualified person and be in accordance with all municipal and national electrical codes and pertinent industry standards should be verified before installation.
3. Use this unit only in the manner intended by the manufacturer. If you have any questions, contact the manufacturer.
4. Moving Parts, Disconnect Power supply before opening. ensure that all the nuts and screws are securely fastened before restarting the unit.
5. Before servicing or cleaning the unit, switch power off at service panel and lock the service disconnecting means to prevent power from being switched on accidentally. When the service disconnecting means cannot be locked, securely fasten a prominent warning device, such as a tag, to the service panel.
6. When cutting or drilling into wall or ceiling, make sure that you do not damage electrical wiring and other hidden utilities.
7. To reduce the risk of fire, use only solid metal ductwork. Do not use any accessories not recommended by the manufacturer.
8. When performing installation, servicing or cleaning these unit, it is suggested to wear safety glasses and gloves.
9. Do not use this unit for commercial purpose.
10. For residential use only. The unit must be grounded.
11. Do not install in a cooking area.
12. This unit is not designed to exhaust combustion and/or dilution air for fuel burning appliances.

⚠ CAUTION ⚠

1. Turn the unit OFF during construction or repair to avoid filter blockage.
2. Exhaust air outside - Do not intake / exhaust air into spaces within walls, crawl spaces, garage, or into attics.
3. Unit has to be installed in accordance to National and Local Building Code.
4. When leaving house for a long period of time (more than two weeks), a responsible person should check if unit operates adequately.
5. Published efficiencies are based on balanced air-flows on supply and exhaust.

PACKAGING INSPECTION

Open the box and check to make sure all the parts and accessories are present and in good condition. If you find any parts missing or any shipping damage please contact factory or our distributor immediately.

CONTENTS

Parts List (Delux/Superior ECM)	1
Parts List (Maxum ECM)	2
Wiring Diagram	
• Control Board	3
• HRV/ERV Layout	3
• Wall Control Units and Timer Switches	4
• 120VAC Light/Switch Options	4
• Furnace / Fan-Coil / Heat Pump Interlock	5
(For a furnace connected to a cooling system)	
- Standard Furnace Interlock Wiring	5
- Alternate Furnace Interlock Wiring	5
HRV/ERV Operational Modes Functionality	6
Timer Switch and Intermittent Switch (Optional)	7
Programming Instructions for Wall Control Unit (WC100)	
Function:	
• Switching Between the HRV/ERV Operational Modes ..	8
• Adjusting Humidity Setpoint	8
• Setting Internal Programming Parameters	9
• Displaying Errors	10
HRV and ERV Typical Installations	
• <u>For Houses</u>	11
- Fully Ducted System	
- Furnace Return Air-duct connection	
- Semi Ducted System	
• <u>For High Rise Condominium</u>	11
- Fully Ducted System	
- With Fan-Coil System	
• Horizontal	12
• Vertical	12
• Access Door installation	
• Drain Connection	13
Air Flow Balancing	
• Balancing Procedure	14
• Pitot Tube Air Flow Balancing	14
Maintenance	
• Regular Maintenance	15
• Annual Maintenance	16
Troubleshooting	17
Climate Zone	18

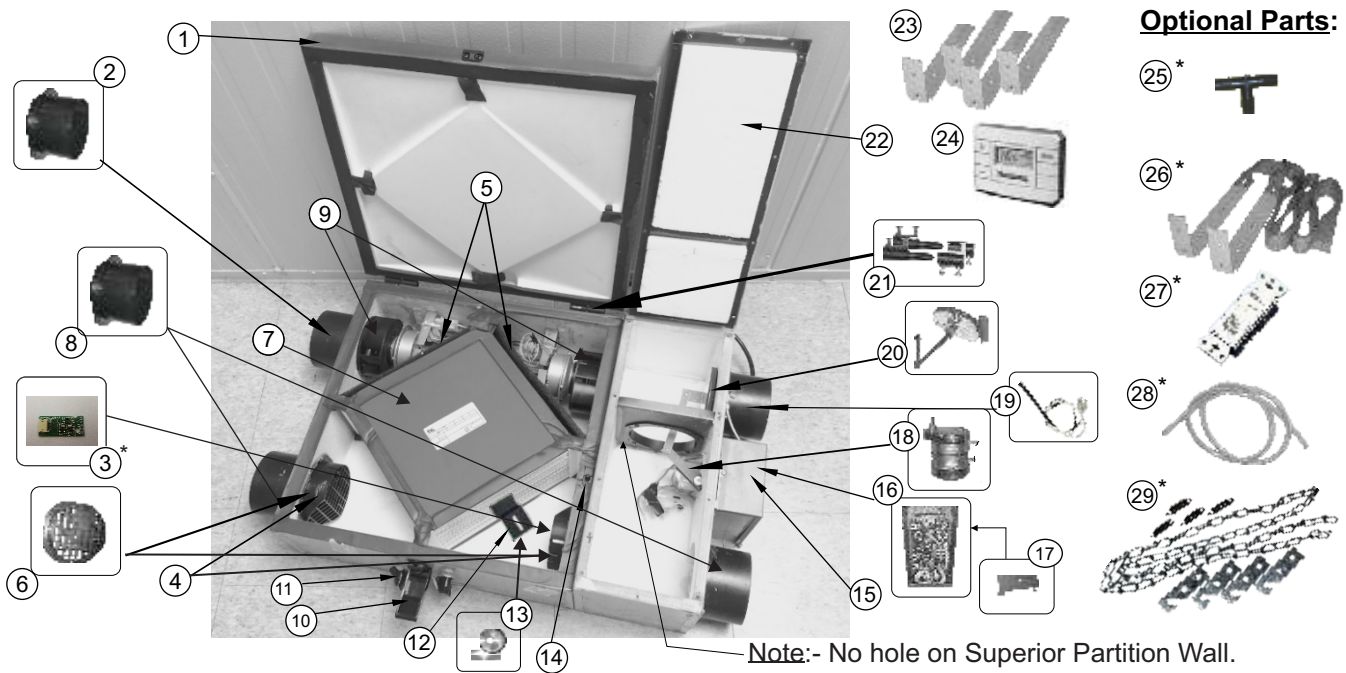

Reference	Description	Part no.	RHRV-D100A	RHRV-D100P	RERV-D100
			QTY.	QTY.	QTY.
1	HRV / ERV - Lid, Pan Assembly	9315	1	1	1
2	Polypropylene Collar 5" Dia.	014043C	2	2	2
3*	Humidity Sensor	9316	1	1	1
4	Air Flow Sensor Pair (For Deluxe auto balance unit only)	9334	2	2	2
5	Filter 12" x 7" (MERV-4)	9358	2	2	2
6	Airflow Diffuser (For Deluxe auto balance unit only)	9353	2	2	2
7	Polypropylene Core	9313	n/a	1	n/a
	Enthalpy Core	9314	n/a	n/a	1
8	5"Ø Polypropylene Backdraft Damper	014043	2	2	2
9	Motor - Exhaust/ Supply (ECM)	013085	2	2	2
10	Adjustable Door Latch	9319	1	1	1
11	Drain Spout Assembly	9320	2	2	2
12	Core Locking Bracket	9321	1	1	1
13	Nut	014016	1	1	1
14	Safety Switch	9322	1	1	1
15	Electrical Box Cover	9323	1	1	1
16	Main Control Board (ECM)	9356ECM	1	1	1
17	Main Control Board Bracket	9355	2	2	2
18	Defrost Motor (For Deluxe units only)	9325	1	1	1
19	Temperature Sensor	9326	1	1	1
20	Defrost Damper Assembly (For Deluxe units only)	9327	1	1	1
21	Door Hinges	9328	1 Set	1 Set	1 Set
22	Extension Box Cover	9329	1	1	1
23	Mounting Brackets	011135	4	4	4
24	Wall Control Unit (WC100)	9335	1	1	1
25*	" T " Connector	9330	1	1	1
26*	Webbing/Brackets/Ladder Locks	9332	2 Sets	2 Sets	2 Sets
27*	Electronic Timer Switch (TC100)	9349	1	1	1
28*	Drain Pipe	9331	1	1	1
29*	Chains/Springs/Brackets	9354	1 Set	1 Set	1 Set

Maxum Series

model:
RHRV-S200P (ECM)
 Polypropylene Core
RERV-S200ES (ECM)
 Enthalpy Core

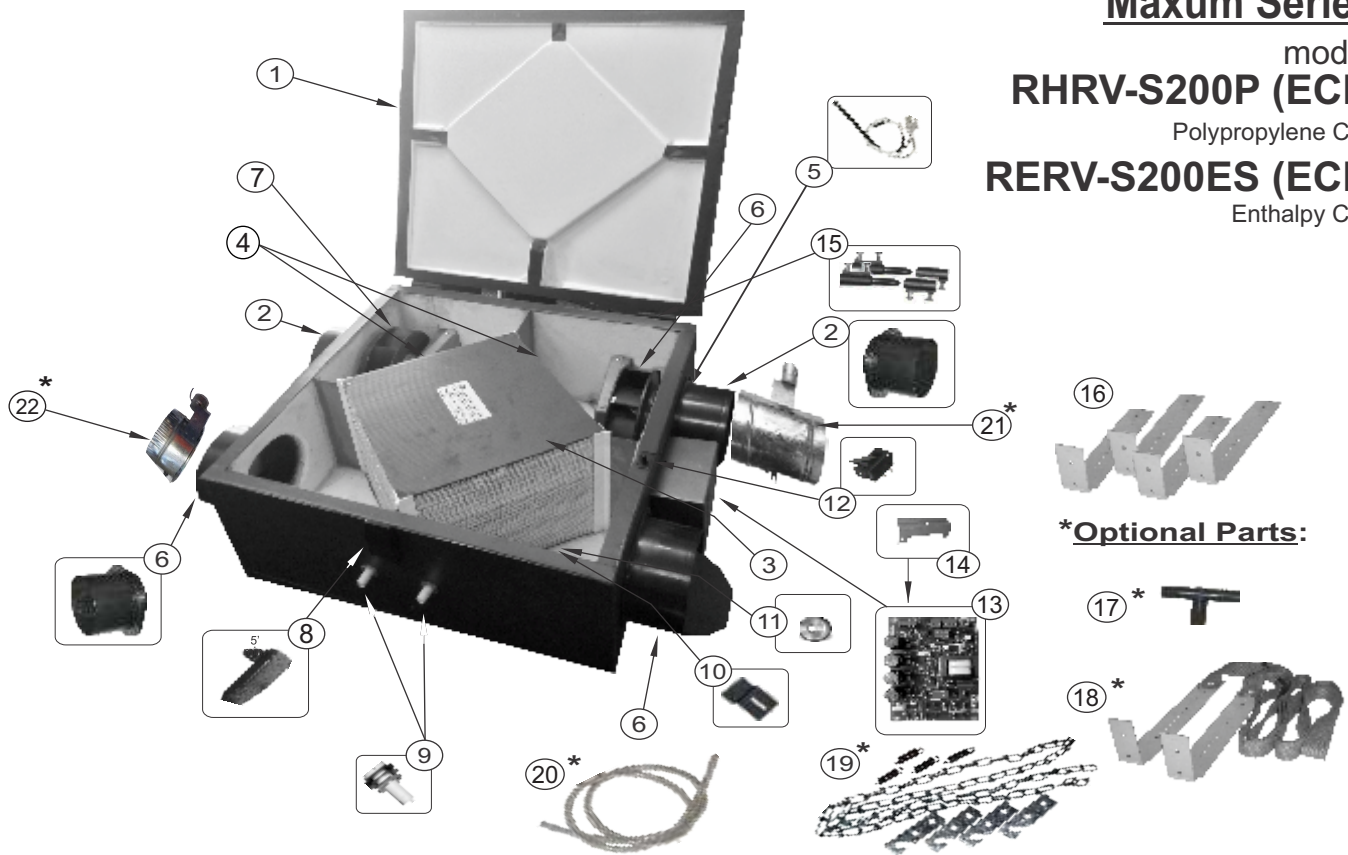

***Optional Parts:**

Reference	Description	Part no.	RHRV-P100A	RHRV-P100P	RERV-P100
			QTY.	QTY.	QTY.
1	HRV / ERV - Lid, Pan Assembly	9391	1	1	1
2	Polypropylene Collar 6" Dia.	PBD6C	2	2	2
3	Polypropylene Core	9393	n/a	1	n/a
	Enthalpy Core	9394	n/a	n/a	1
4	Filter 10 1/2" x 12" (MERV - 4)	9395	2	2	2
5	Temperature Sensor	9326	1	1	1
6	6"Ø Polypropylene Backdraft Damper	PBD6	2	2	2
7	Blower - Supply / Exhaust (ECM)	013070 ECM	1	1	1
8	Adjustable Door Latch	9319	1	1	1
9	Drain Spout Assembly	9320	2	2	2
10	Core Locking Bracket	9321	1	1	1
11	Nut	014016	1	1	1
12	Safety Switch	9322	1	1	1
13	Main Control Board (ECM)	9356 ECM	1	1	1
14	Main Control Board Bracket	9355	2	2	2
15	Door Hinges	9328	1 Set	1 Set	1 Set
16	Mounting Brackets	011136	4	4	4
17*	" T " Connector	9330	1	1	1
18*	Webbing/Brackets/Ladder Locks	9332	2 Sets	2 Sets	2 Sets
19*	Chains/Springs/Brackets	9354	1 Set	1 Set	1 Set
20*	Drain Pipe	9331	1	1	1
21*	120V Motorized spring return damper 6"Ø	9397	1	1	1
22*	Motorized damper spring return built-in 6"Ø	9398	1	1	1

Control Board

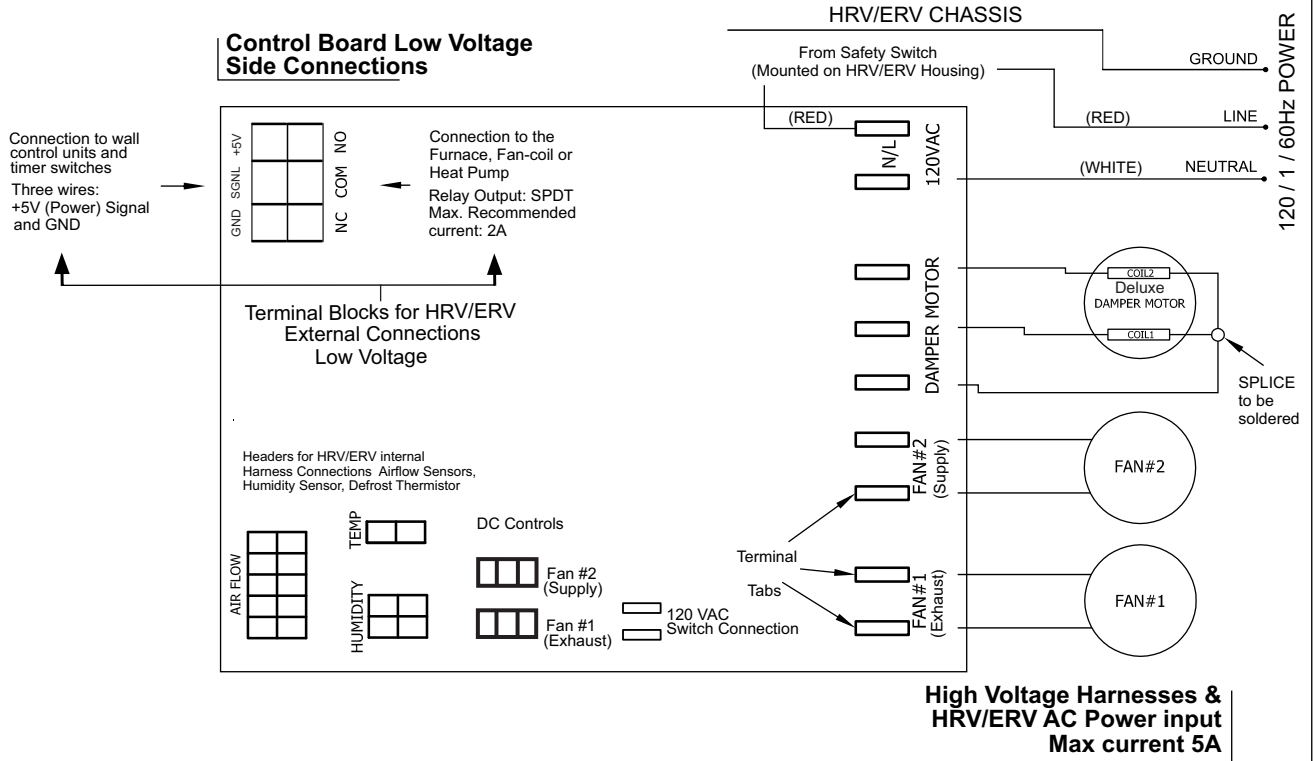

HRV/ERV Layout

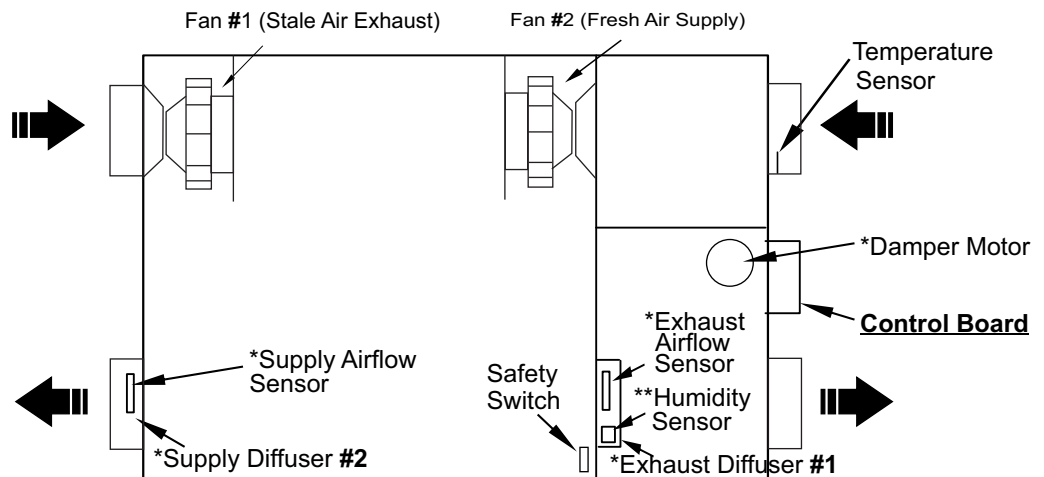

Note:-
Air Flow Sensors, Diffusers and Air Flow Harness are for auto balancing unit only.

*Deluxe autobalancing model only.
** Optional.

Wall Control Units and Timer Switches (Low Voltage, 5 VDC)

Option 1:

Wall Control (WC 100)
 20/40/60 Min. Timer (TC 100 - 5V)
 Intermittent Switch (IC 100 - 5V)

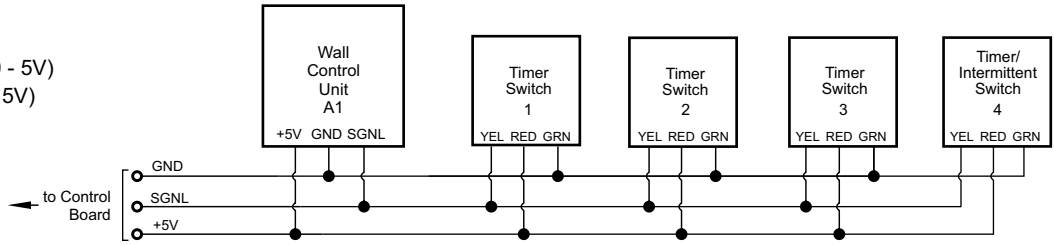

Option 2:

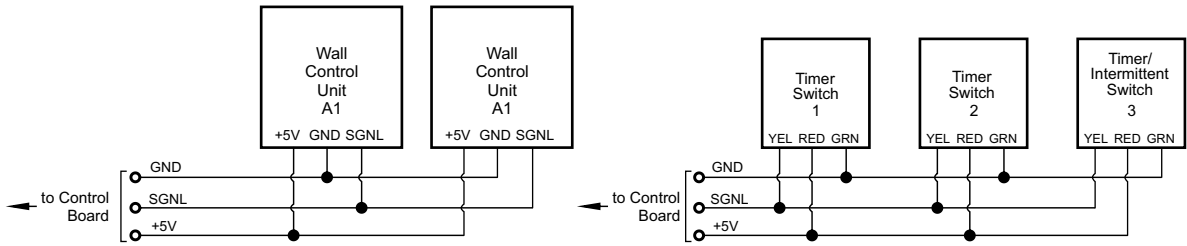

Option 3:

(Refer to page 8 to set address A1, A2, & A3)

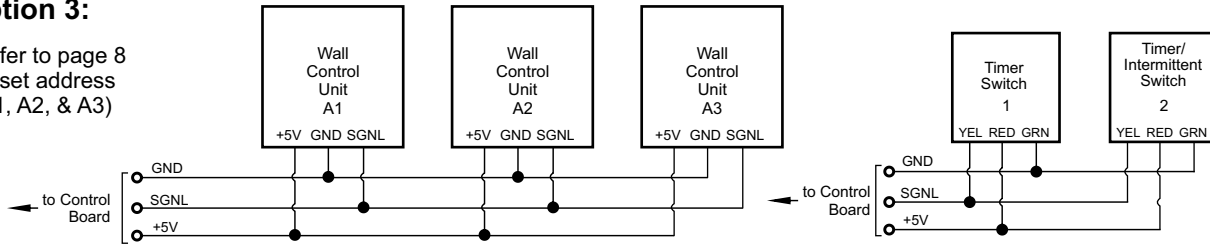

Note: 3 Wall-controls and 2 Timer switches or 2 wall controls and 3 Timer switches or 1 wall control and 4 Timer switches can be connected to control board of HRV/ERV by using three 26 AWG (min.) Copper wires as shown. **Maximum wire length is 75ft.** (Only 1 intermittent switch can be connected as shown above)

120 VAC Light/Switch Options

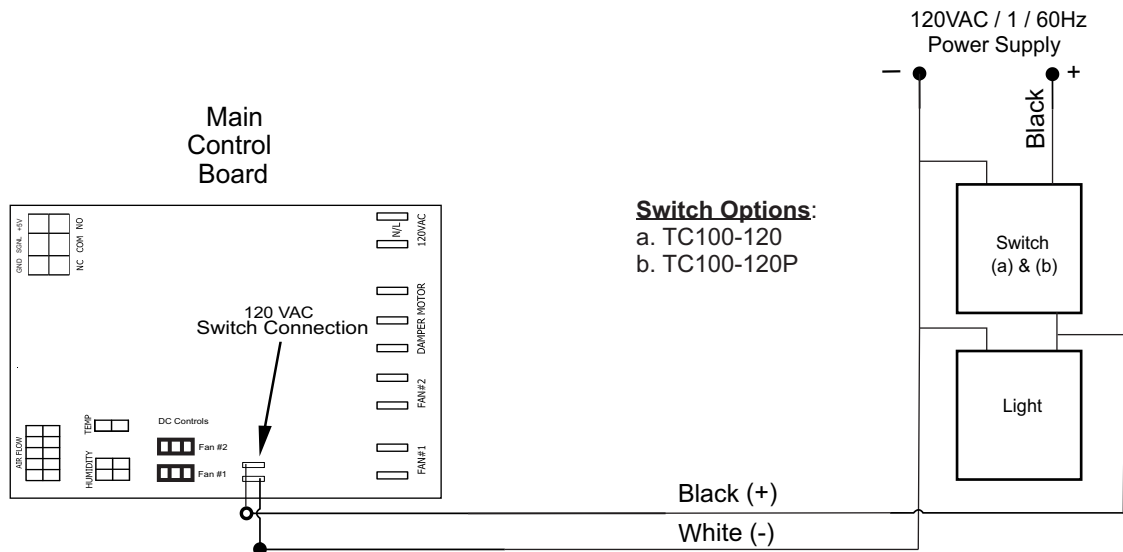



Furnace / Fan-Coil / Heat Pump Interlock:

⚠ WARNING ⚠

Never connect a 120 volt AC circuit to the terminals of the furnace/fan-coil/heat pump interlock (Standard Wiring). Only use the low voltage class 2 circuit.

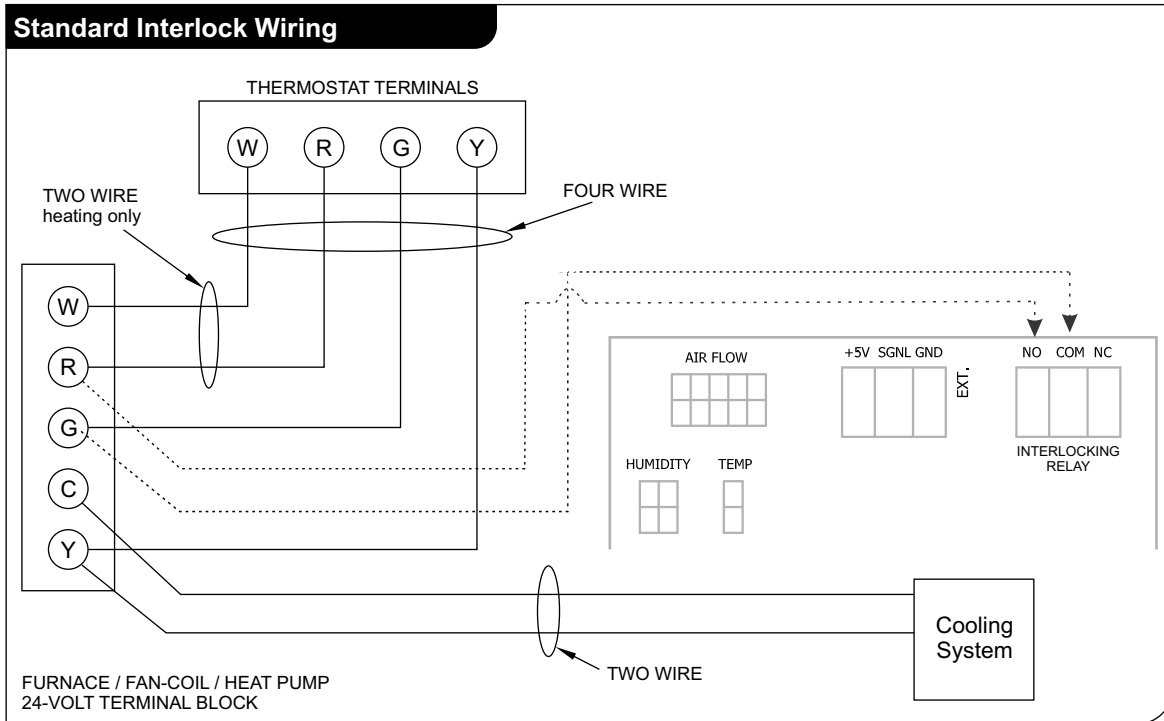

For a furnace connected to a cooling system:

On some older thermostats, energizing the R and G terminals at the furnace has the effect of energizing Y at the thermostat and thereby turning on the cooling system. If you identify this type of thermostat, you must use the "Alternate Interlock Wiring".

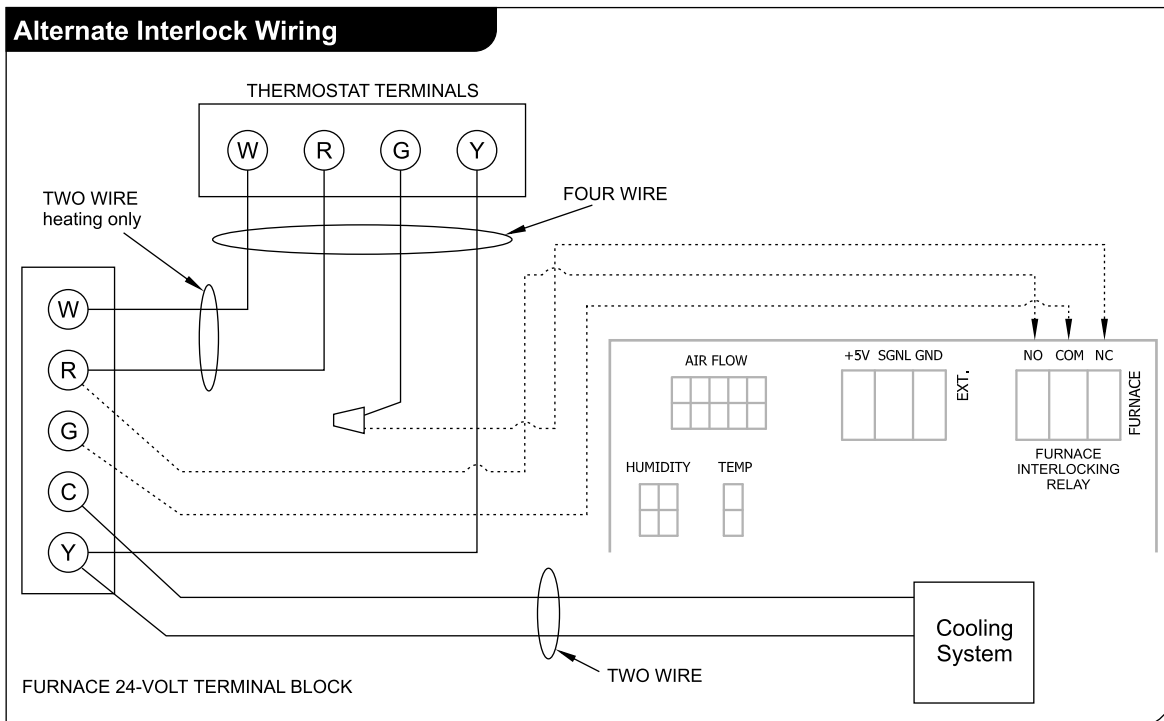

Off Mode: HRV/ERV fans are off. Defrost damper is closed to prevent cold air from entering the unit.

Normal Mode: In Normal mode HRV/ERV fans run and the unit exchanges indoor air with outdoor air. The airflow exchange can be adjusted in four preset airflow values. Normal Mode is intended to be requested by the user for long time HRV/ERV operation.

High Ventilation Mode: In High Ventilation Mode the HRV/ERV fans run and the unit exchanges indoor air with outdoor air, as in Normal Mode, but the airflow level is much higher. The airflow exchange can be adjusted in four preset airflow values. High Ventilation Mode is intended to be requested by the user if he/she requires quick air exchange in the house. The HRV/ERV can run in High in Ventilation mode for unlimited period of time or for one of three preset timeout periods: 1,2 or 3 hours.

Energy Saving Mode: The HRV/ERV will switch to Energy Saving Mode when it is requested by the User, from the Wall Mount Unit. In Energy Saving Mode HRV/ERV will automatically run in Auto mode 20 minute per every 4 hours. The rest of the time the unit will stay in OFF mode. The defrost damper is closed to prevent cold-air from entering the unit and the first running will start immediately after the HRV/ERV was set to Energy Saving mode.

Defrost Mode: In Defrost mode the HRV/ERV re-circulates or only exhausts indoor air through the heat exchanger, for a prescribed length of time over a prescribed time period. The unit automatically switches to Defrost mode, when the outdoor air is below -5°C , and return to the last requested mode when the outdoor air temperature becomes above -5°C . The period of time when the unit re-circulates or exhausts indoor air, will lengthen as the external temperature lowers. While re-circulating ("Nd" mode), the unit runs in High Ventilation mode with exhaust fan shutting off and damper closed. While non-recirculating (exhausting/FC), the exhaust fan runs in High Ventilation Mode with supply fan shutting off and damper closed. Outdoor temperature is measured by a temp. sensor located in the HRV/ERV outdoor air intake duct. The Defrost Mode is an automatic mode which cannot be enabled/disabled by the user, but the user can select from two defrost methods - recirculation "Nd" or non-recirculation "FC" and also one of nine preset maps for the defrost period length depending on the outdoor temperature and type of heat exchanger / core. (see page 6)

Humidity Mode: In Humidity Mode, the HRV/ERV switches to High Ventilation Mode automatically when the indoor humidity level exceeds the humidity set point, and returns to Normal Mode when the humidity level becomes lower than the set point. The humidity level is measured by an external humidity sensor mounted in the inlet of HRV/ERV station #4. The Humidity Mode can be disabled by the user by setting the humidity set point to zero.

Recirculation Mode: When the User requests Recirculation Mode from the Wall Mount Unit, the HRV/ERV Control will place the supply fan into high speed with damper closed. Exhaust fan is off in this mode (when selected "Nd" mode on wall mount for Deluxe unit).

Note:- If "FC" mode is selected on the wall mount, the exhaust motor goes into high speed and supply motor stops (Superior and Maxum unit only).

Manual Balancing Mode: (Optional for unit without automatic balancing) In manual balancing Mode, fan speed can be manually adjusted by operating Wall Mount display in programming mode. (refer to page 7)

Timer Switch
Model # TC100-5V
(5 VDC)



Intermittent Switch
Model # IC-100-5V
(5 VDC)



Timer Switch
Model # TC-100-120
(120 VAC)



Timer Switch (Programmable)
Model # TC-100-120P
(120 VAC)



1. TC100-5V

The Timer Switch Unit consists of 3 LEDs and 1 push button. The Timer Switch Unit can put the unit in to High Speed Mode for the set time on the Timer Switch (20 min, 40 min, 60 min).

When timed cycle is complete the unit returns to normal run mode set on Wall Control unit.

When a Timer Switch is activated, the other Timer Switch Blinks its LED and Wall Mount Unit lights up its REMOTE icon on LCD indicating that HRV/ERV has been forced in to High Speed Mode.

If there are more than one Timer Switch activated, the Timer Switch having longest time takes control and only that Timer Switch can turn off the timer switch operation.

All 3 LEDs will blink to indicate error if the Control Board reports error or the Timer Switch loses communication with the Control Board.

2. IC-100-5V

The Intermittent Switch allow user to select one of the following operation mode:

1. Low Speed Mode
2. High Speed Mode
3. Intermittent Mode and
4. OFF mode (optional - contact factory for details and to order).

On initial power up, Low Speed Mode is on and the first LED is on.

On a button press, it goes into High Speed Mode and the second LED is on. On another button press, it goes to Intermittent Mode and the third LED is on.

In Intermittent Mode, HRV starts with 20 minutes low speed which is followed by 40 minutes off.

The cycle continues until intermittent mode is exited.

On a button press, it goes into OFF mode and all LEDs are OFF (optional).

3. TC-100-120

The Timer Switch activates the HRV/ERV on high speed for 5,10,15 & 30 minutes.

Once an option is selected, the LED will turn on, indicating the duration of the high speed mode.

Once the duration is up, the unit will go back to normal mode and the LED will turn off.

4. TC-100-120P

The TC-100-120P is a 24 hour programmable Timer Switch that allows for the unit to be shut off for a pre-selected duration and comes back on when the time delay has been achieved. It is suitable for Superior Series and Compact Units.

Important Note: When installing timers or time delay switches, make sure that they are for appropriate HRV/ERV models.



Now available with back light for better viewing.

Normally there will be only one Wall Control Unit connected to Control Board. Multi Wall Control Unit (up to three) is also supported (see page 2). All Wall Control Units will have the same priorities over each other. It means that if multiple Wall Control Units command Control Board differently, the latest command will be executed by the Control Board. Each Wall Control Unit has different address for communication purpose. The addresses for Wall Control Units will be A1,A2, and A3. The addresses can be set by entering into programming mode (see page 7).

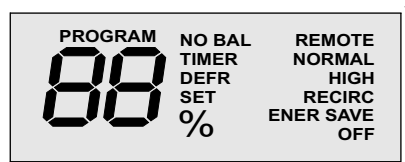

All Available LCD display electrodes

Functions:

Switching between the HRV/ERV Operational Modes

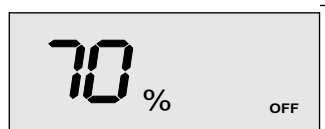

Display after power up. Mode OFF. Current humidity 70%

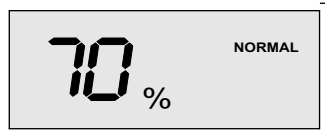

Press MODE button. Mode changed to NORMAL. HRV/ERV runs at normal airflow.

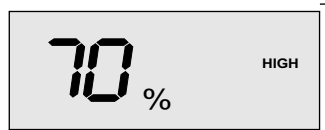

Press MODE button. Mode changed to HIGH HRV/ERV runs in High Ventilation airflow.

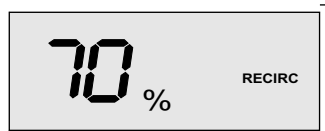

Press MODE button. Mode changed to RECIRC. HRV/ERV runs according to the sequence for Recirculation mode.

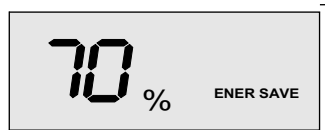

Press MODE button. Mode changed to ENER SAVE. HRV/ERV runs according to the sequence for Energy Saving mode.

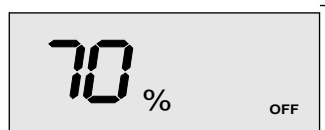

Press MODE button. Mode changed to OFF. HRV/ERV fans are off, no ventilation.

Note:

1. Factory programmed default mode: OFF
2. The Mode to be stored in the non-volatile memory (EEPROM), so in a case of power outage, the system to return in the last selected mode.

It is very important to program wall controller according to HRV / ERV model, core type, CFM requirement etc. before commissioning.

Adjusting Humidity Setpoint

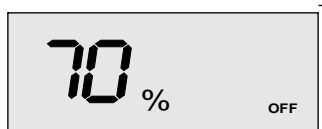

Mode OFF. Current Humidity 70%

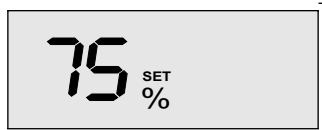

Press either + or - button. The Current Humidity setpoint is displayed 75%.

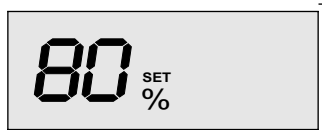

Press + button. Humidity setpoint is incremented.

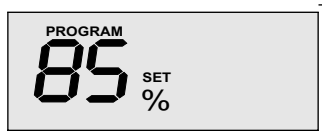

Press + button. Humidity setpoint is incremented.

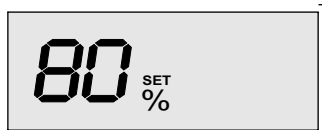

Press - button. Humidity setpoint is decremented.

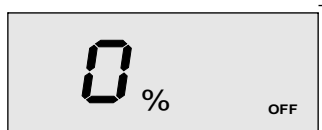

Humidity Mode can be disabled by setting the Humidity setpoint to 0%. Humidity setpoint is between 0% to 85% in 5% increment levels.

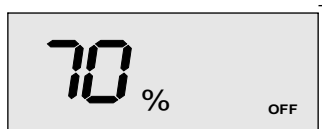

Do not press any button for 10 sec. Display turns back to the current Humidity 70%, OFF mode. The Humidity setpoint has been changed from 75 to 80%.

Note:

Factory programmed default humidity setting: 50%.

Setting Internal Programming Parameters

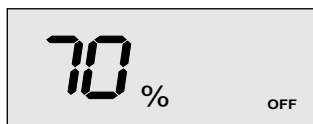

Mode OFF. Current Humidity 70%

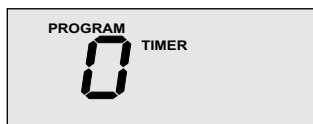

Press both + and - buttons for 4 sec. Unit switches to Programming Mode. The first programming parameter is the High Ventilation Timeout Timer. The current value is 0, which means timer is off.

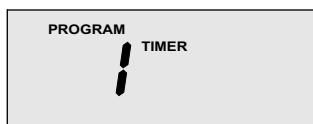

Press + button. Timeout Timer changes to 1 hour.

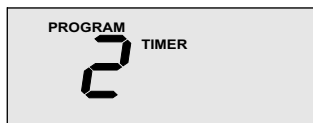

Press + again. Timeout Timer changes to 2 hours.

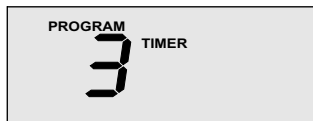

Press + again. Timeout Timer changes to 3 hours. When you select the desired timeout (0-3), press the MODE button. Timeout timer is reprogrammed with the new value.

NOTE: Factory programmed default TIMER value 0.

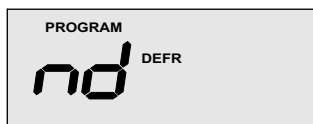

After pressing the MODE button, the unit switches to Defrost cycle mode selection. The current Defrost cycle mode is recirculation (nd).

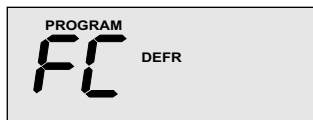

Press + button. Defrost cycle mode changes to fan cycle (FC). When you select the desired defrost cycle mode, press MODE button. Defrost cycle mode is reprogrammed w/ the new value.

NOTE: Factory programmed default is recirculation defrost "nd".

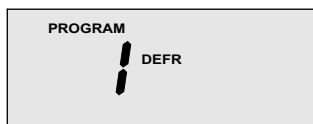

After pressing the MODE button, the unit switches to Defrost Map selection. The current Defrost map is #1.

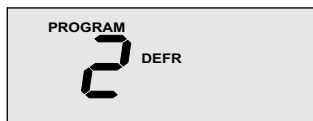

Press + button, Defrost Map changes to #2.

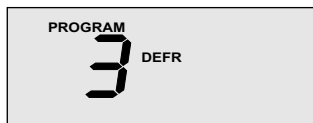

Press + button, Defrost Map changes to #3.



Press + button, Defrost Map changes to #4. When you select the desired Defrost Map # (1-9), press MODE button. Defrost Map is reprogrammed with the new number.

NOTE: There are totally 9 Defrost Maps. **Map1-3 are for Aluminum Core (RHRV-D100A). Map 4-6 are for Polypropylene Core (RHRV-D100P). Map 7-9 are for ERV Core (RERV-D100).** Factory programmed default DEFR values are Map-1 for RHRV-D100A, Map-4 for RHRV-D100P & Map-7 for RERV- D100.



After pressing the MODE button, the unit switches to Normal Mode Airflow setting. The current value is n1. (which gives you **app. 63 CFM**).

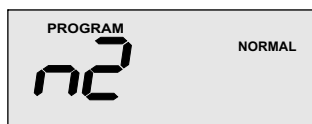

Press + button. The value is changed to n2. (that gives you **app. 75 CFM**).

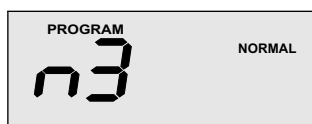

Press + button. The value is changed to n3. (gives you **app. 84 CFM**).

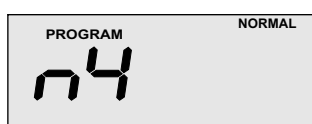

Press + button. The value is changed to n4. (which gives you **app. 95 CFM**).

When you select the desired setting for Normal Mode airflow (n1 to n4), press MODE button. The Normal Mode Airflow setting is reprogrammed with the new value.

NOTE: Factory programmed default value n2.

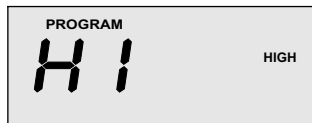

After pressing the MODE button, the unit switches to High Ventilation Mode Airflow setting. The current value is H1 (which gives you **app. 80 CFM**).

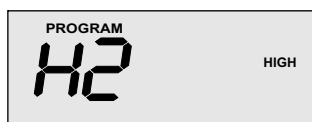

Press + button. The value is changed to H2 (which gives you **app. 100 CFM**).

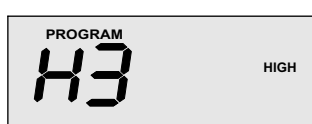

Press + button. The value is changed to H3 (which gives you **app. 125 CFM**).

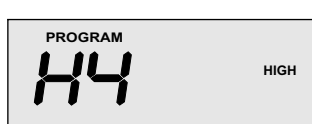

Press + button. The value is changed to H4 (which gives you **app. 155 CFM**).

When you select the desired setting for High Ventilation Mode airflow (H1 to H4), press MODE button. The High Ventilation Mode Airflow setting is reprogrammed with the new value.

NOTE: Factory programmed value H2.



After pressing the MODE button, the unit switches to Airflow Balancing disable/enable setting. The current value is enabled. **(Automatic Balancing mode)**

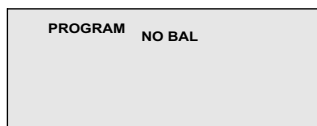

Press + button. The value is changed to disabled. **(Manual Balancing mode - for units without built in automatic Electronic Air Balancing)**

Press + button again. The value is changed to enabled. When you select the desired setting, press MODE button. The setting is reprogrammed with the new value.

If Airflow Balancing is enabled, after pressing the MODE button, the unit jumps to Wall Mount address setting.

Else if Airflow Balancing is disabled, after pressing the MODE button, the unit switches to **supply fan manual Airflow adjustment mode.**

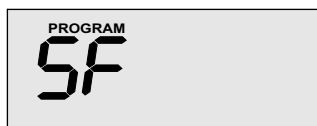

"SF" is displayed when the unit is in supply fan manual Airflow adjustment mode.

Press + or - button to increase or decrease supply fan speed. "SF" blinks when the button is depressed. It may take several minutes to speed up or slow down.

Release of + or - button stops supply fan speed change.

The changed supply fan speed is stored in non-volatile memory which will be used from now on for the current airflow settings (N1-N4 and H1-H4) can be manually changed and stored in non-volatile memory.

Note: Enabling of balancing mode will cause manual fan speed change back to default settings.

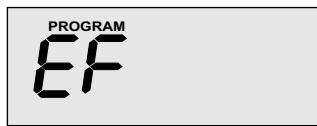

After pressing the MODE button, the unit switches to **exhaust fan manual adjustment mode.** "EF" is displayed when the unit is in exhaust fan manual airflow adjustment mode.

Press + or - button to increase or decrease exhaust fan speed. "EF" blinks when the button is depressed. It may take several minutes to speed up or slow down.

Releasing of + or - button stops exhaust fan speed change.

Note: In manual balancing mode, we recommend SF & EF values are adjusted by professional balancer or qualified contractor.



The changed exhaust fan speed is stored in non-volatile memory which will be used from now on for the current airflow settings (N1-N4 and H1-H4) can be manually changed and stored in non-volatile memory.

Note: Enabling of balancing mode will cause manual fan speed change back to default settings.

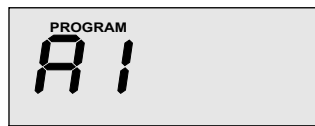

After pressing the MODE button, the unit switches to wall control address setting. The current value is A1. (Wall control #1)

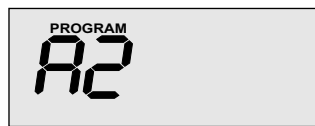

Press + button, The value is changed to A2. (Wall control #2)



Press + button, The value is changed to A3 (Wall control #3). When you select the desired address, press MODE button. The address is reprogrammed with the new value.

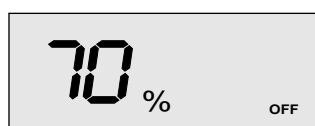

After pressing the MODE button, the unit return back to normal operational mode. The new programmed settings are stored in the memory, & the HRV/ERV will operate according to them.

Note:

- Default Wall Unit Address is A1. If multiple Wall units are installed, they must have different addresses (i.e. A2,A3) in order to make communication work.
- If the Wall Unit is in Programming mode and there is no button pressing for timeout period of 60 sec., the Unit returns automatically back in normal operational mode.

Displaying Errors

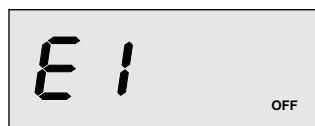

Loss of communication with the Control Board. HRV/ERV switched to OFF mode automatically.



Defrosting Temperature Sensor Failure. Blinks with the current operational display. HRV/ERV does not perform defrost cycles.

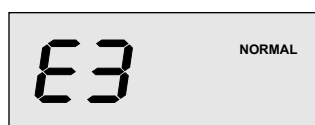

Airflow Sensor Failure. Blinks with the current operational display. HRV/ERV runs at fixed default Low and High fans speeds.(Auto balancing unit only)

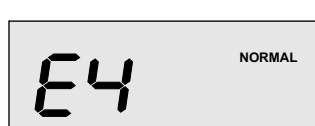

Humidity Sensor Failure. Blinks with the current operational display. HRV/ERV does not run in High Humidity mode.

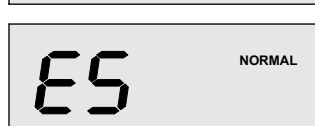

Fans Failure. Blinks with the current operational display. HRV/ERV stops fans, closes damper & opens furnace / fan-coil / heat pump interlock relay. (Auto balancing unit only)

Note:- E3 & E5 will not be displayed on non-balancing unit. see page-14 for possible causes and solutions.

Typical Installations for House

Fully Ducted System

This is a stand alone HRV/ERV system which is not connected to a force air system. Stale air is drawn from key areas of the home (bathroom, kitchen) while fresh air is supplied to main living areas.

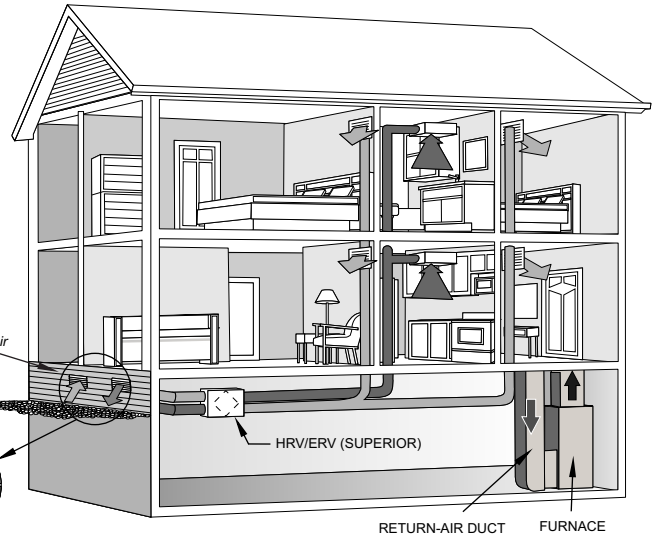
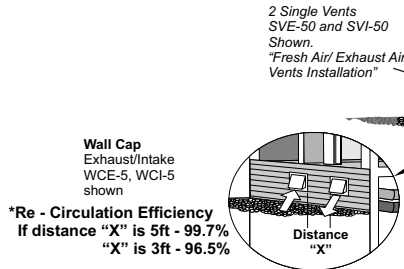
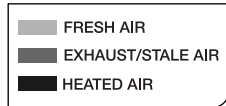

Furnace Return Air-duct Connection

DVS100
Double Vent with hood shown "Fresh Air/Exhaust Air Vent installation"

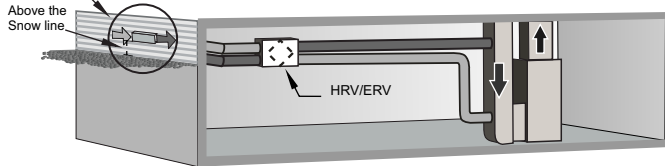

Semi Ducted System

Double Vent with Extruded Aluminum Grille
DVG200 shown "Fresh Air/Exhaust Air Vent installation"

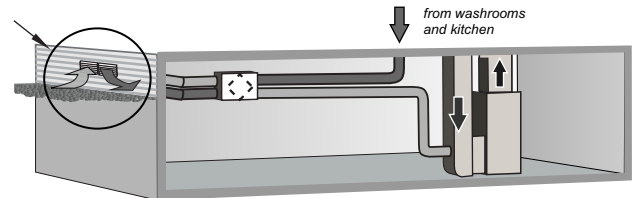

- This installation enables stale air to be drawn from the poorest air quality areas of the home (washrooms & kitchen)

Note:

- It is recommended that the furnace blower run continuously or HRV/ERV operation be interlocked with the furnace blower to evenly distribute the fresh air throughout the house.
- A backdraft damper is required in the exhaust air duct to prevent outdoor air from entering the unit when the Furnace / Air handler is running and the unit is in Standby, OFF or in Recirculation.

Installation Options for High-Rise Condominium

Fully Ducted System

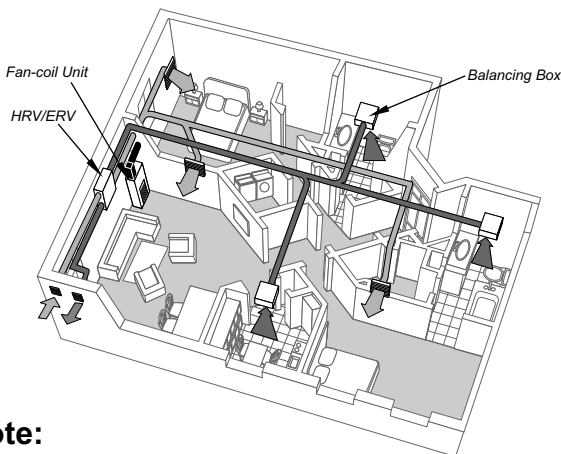

Note:

- All Exhaust Vents must be installed min. 5 ft away from sidewalls.

With Fan-Coil System

- Fresh air from outside should be installed on Fan-coil supply side (HRV/ERV station #2) and HRV/ERV should be interlocked with Fan-coil unit.

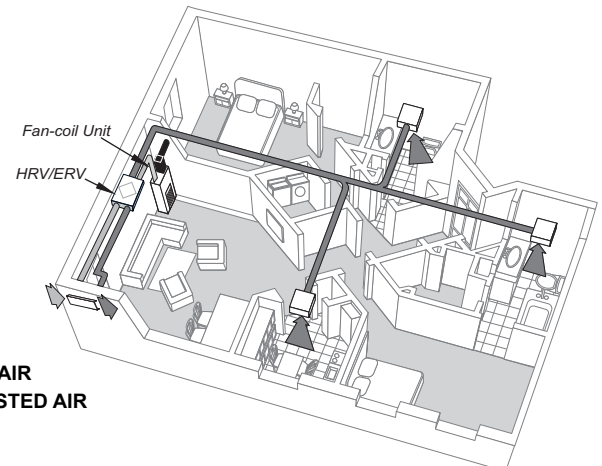

HORIZONTAL

- 32" clearance is recommended for cleaning of the core/servicing the unit. (use appropriate access door size)
- Dampers are installed for horizontal installation. For vertical installation both dampers have to be turned so they can open properly and close when there is any backdraft.
- **Make sure no screw will interfere the function of the backdraft damper flaps while installing the duct work to the HRV/ERV.**

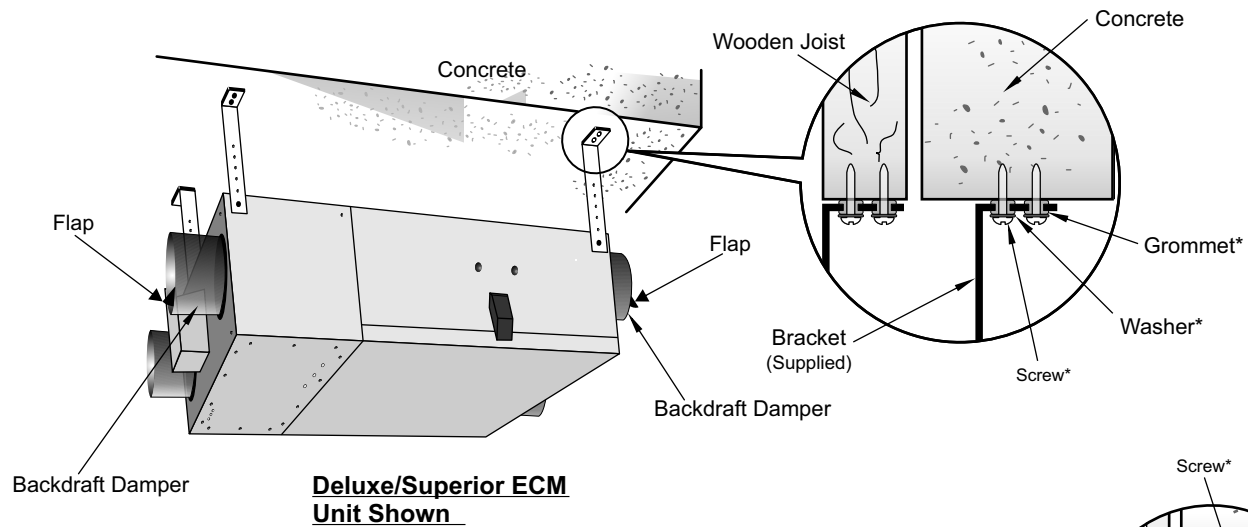

VERTICAL

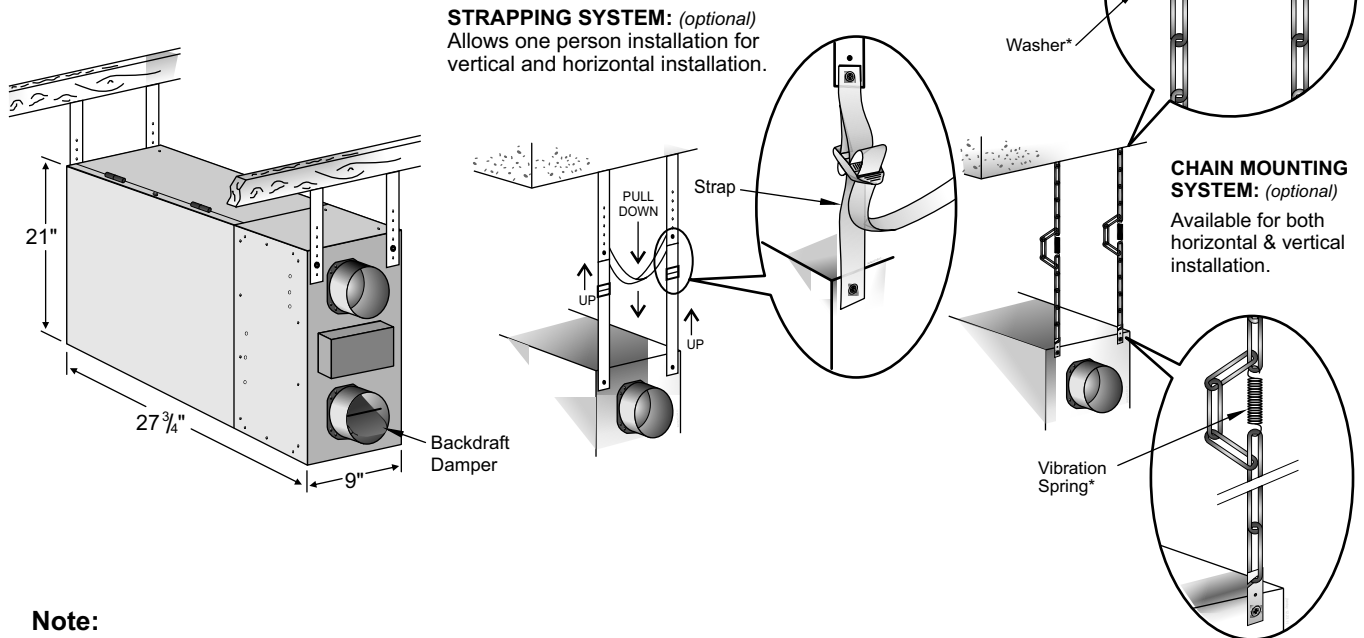

Note:

- After installation make sure the HRV/ERV is properly leveled. If not levelled correctly, then defrost will not perform effectively and/or unit may frost in winter.
- Also make sure you have proper defrost on wall - controller according to HRV / ERV model no. / core type.
 Map 1-3 are for Aluminum Core (RHRV-D100AES). Map 4-6 are for Polypropylene / Plastic Core (RHRV-D100PES).
 Map 7-9 are for ERV / Enthalpy Core (RERV-D100ES).

Typical Installations of Single Vents & Access door

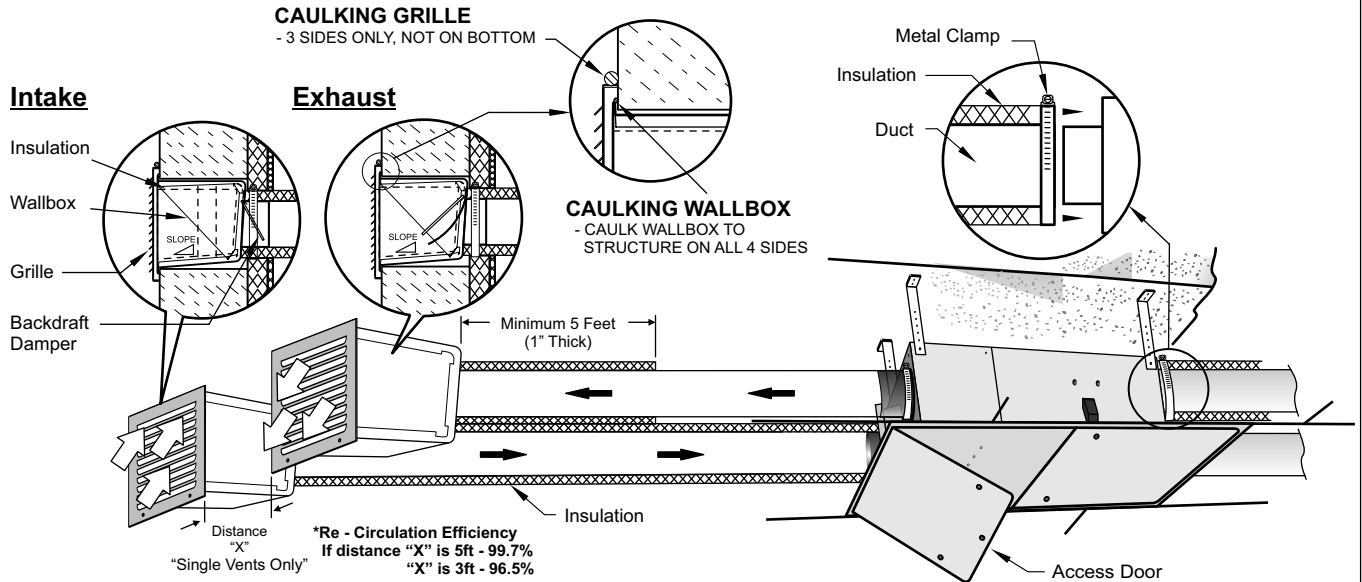

Note:
 -Fresh air intake and supply duct must be totally insulated. Exhaust duct must be 5 feet insulated from the wall. In colder climate, it is recommended to insulate all exhaust and supply ducts.

-Use appropriate access door size and install on proper location for easy access to all HRV/ERV components for routine check and maintenance of the unit.
 For more info visit <http://www.reversomatic.com/HRV&ERV/Accessories>

Drain Connection

During defrost cycle the HRV unit may produce some condensation and the water should flow into a nearby drain.

The HRV cabinet has pre-punched holes (two on side and one on the door) for the drain, in order to keep the drain pan intact, *hand tighten* the plastic drain spout to the unit using the gasket and nuts.

For Vertical installation

Cut two sections of 1/2" drain pipe and connect the other ends to the drain spout then connect to "T" connector. Connect a drain line and create a **P-trap** to prevent the unit from unpleasant odours from drain source. Tape or fasten base to avoid any bends.

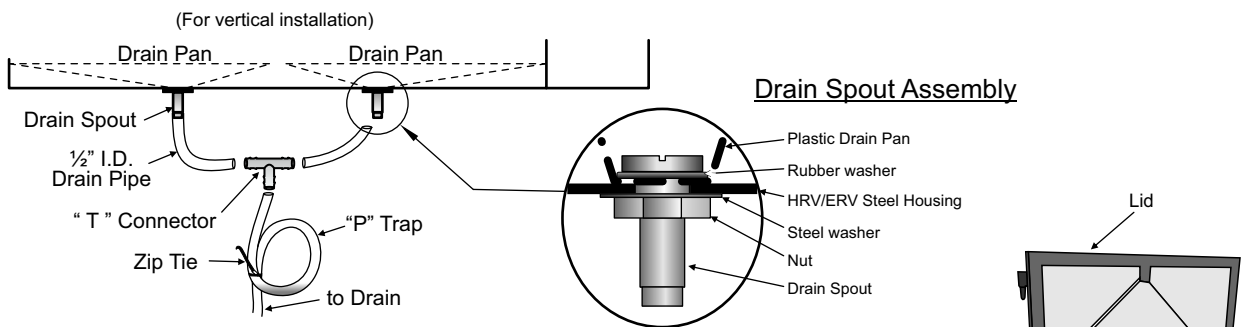

Note:
For Horizontal installation, connect only 1 drain spout assembly on lid / door. cut one 1/2" drain pipe and connect one end to the drain spout and the other end to the drain line. Don't forget to create a P-trap as shown above.

Use this drain for horizontal installation

⚠ CAUTION ⚠

The HRV and all condensate lines must be installed in a space where the temperature is maintained above the freezing point or freeze protection must be provided.

For units without built-in true Automatic Electronic Air-balancing and for cross verification only

Balancing Procedure

It is required to have balanced air flows in an HRV/ERV. The volume of air brought in from the outside must equal the volume of air exhausted by the unit while running at normal speed. If the air flows are not properly balanced, then:

- The HRV/ERV may not function at its maximum efficiency
- A negative or positive air pressure may occur in the house or condo
- The unit may not defrost properly

Prior to balancing, ensure that:

1. All the HRV/ERV's components are in place and functioning properly.
2. All sealing of the ductwork system has been completed.
3. Set the unit to normal speed.
4. Air flows in branch to specific areas of the house should be adjusted first prior to balancing the unit.
5. After taking reading of both the stale air to the HRV/ERV duct and fresh air to the house duct, the duct with the lower CFM reading should be left alone while the duct with the higher airflow should be slower down to match the lower reading by adjusting dial/speed controller on control board (see board layout on page-4).
6. Return unit to appropriate fan speed for normal operation.

Pitot Tube Airflow Balancing

The following is a method of field balancing an HRV/ERV using a Pitot tube advantageous in situations when flow stations are not installed in the ductwork. Procedure should be performed with the HRV/ERV on normal speed.

The first step is to operate all mechanical systems on most desire speed, which have an influence on the ventilation system, i.e. the forced air furnace or air handler if applicable. This will provide the maximum pressure that the HRV/ERV will need to overcome, and allow for a more accurate balancing of the unit.

Drill a small hole in the duct (about 3/16"), three feet downstream of any elbows or bends, and one foot upstream of any elbows or bends. These are recommended distances but the actual installation may limit the amount of straight duct.

The Pitot tube should be connected to a magnehelic gauge capable of reading from 0 to 0.25 in. (0-62 Pa) or other digital airflow meter. The tube coming out of the top of the pitot is connected to the high pressure side of the gauge/meter and the tube coming out of the side of the pitot is connected to the low pressure or reference side of the gauge/meter.

Insert the pitot tube into the duct; pointing the tip into the airflow. For general balancing it is sufficient to move the pitot tube around in the duct and take an average or typical reading. Repeat this procedure in the other duct. Determine which duct has the highest airflow (highest reading on the gauge). Then slower down that motor speed by adjusting dial/speed controller on control board to match the lower reading from the other duct. The flows should now be balanced. Actual airflow can be determined from the gauge/metre reading. The value read on the gauge is called the velocity pressure and on the flow meter is called air velocity (FPM). The Pitot tube comes with a chart that will give the air flow velocity based on the velocity pressure indicated by the gauge. This velocity will be in either feet per minute or metres per second. To determine the actual airflow, the velocity is multiplied by the cross sectional area of the duct being measured.

Pitot tube and gauge

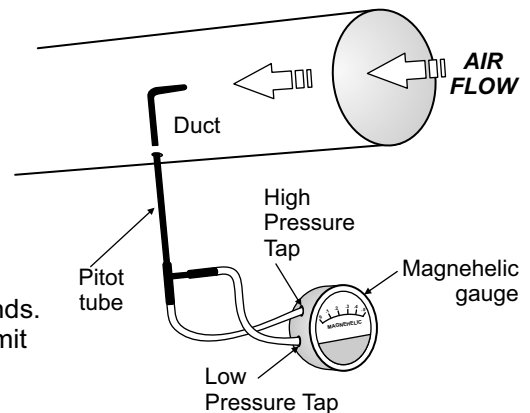

NOTE:
Place the magnehelic gauge on a level surface and adjust it to zero.

Note:(Option #2)

- *For balancing, extension box cover plate is provided with 3 holes on supply side and 3 holes on exhaust side.
- *Do not use pitot tube to open holes in the insulation as it may block/damage the pitot tube.
- *Take 3 readings on each hole and average all 9 readings for supply and same for exhaust.
- *After finish balancing, plug all six holes with plastic plugs provided with the unit.

DUCT DIAM.	CROSS SECTION AREA
5"	0.136 sq. ft.
6"	0.196 sq. ft.

ΔP"		CFM
Ø5	Ø6	
0.010	0.004	50
0.012	0.006	60
0.016	0.008	70
0.022	0.010	80
0.027	0.013	90
0.034	0.016	100
0.041	0.020	110
0.048	0.023	120
0.057	0.027	130

ΔP"= Velocity Pressure in inch

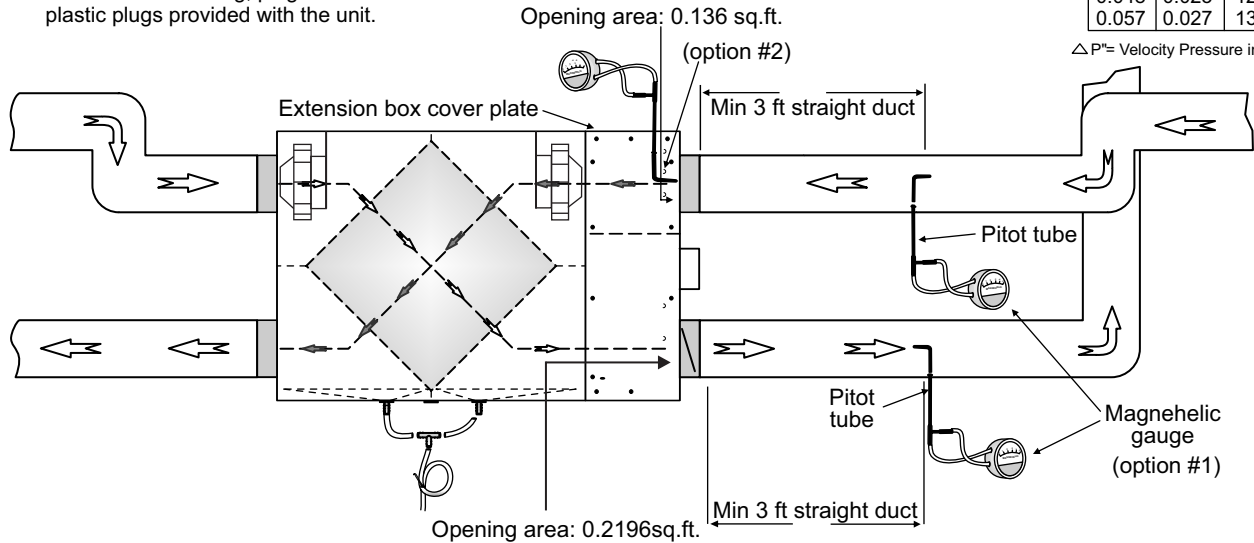

Note: To take more accurate readings, use option #1(if possible).

$$CFM = \text{Opening} / \text{Cross-sectional Area(sq.ft.)} \times \text{velocity(FPM)}$$

The accuracy of the flow reading will be affected by how close to any elbows or bends the readings are taken. Accuracy can be increased by taking an average of multiple readings as outlined in the literature with the Pitot tube.

Maintenance

Regular Maintenance

1. Turn the unit off and disconnect the power supply.
2. Unlatch the door and lift the door panel towards you, hold it firmly and slide it to the left.
3. Clean the inside of the *door* and *drain pan* with a damp cloth to remove dirt and debris that may be present.
4. Clean the *filters*: (twice a year)
 - Remove the filters.
 - Vacuum to remove most of the dust.
 - Wash with a mixture of warm water and mild soap. Rinse thoroughly and shake filters to remove water and let dry.
5. Oil/grease defrost damper levers and hinges.
6. Check air flow sensors twice a year for lint/dust accumulation. If necessary, clean the sensors with a lintfree cloth. Take extra care while handling. make sure supply sensor goes back to supply diffuser and exhaust sensor goes back to exhaust diffuser on same original position.
7. Check the exterior fresh air supply hood:
 - Make sure there are no leaves, twigs, grass, ice or snow that could be drawn into the vent.
 - Partial blocking of this air vent could cause the unit to malfunction.**
8. Reassemble the components, Filters and Door (The door is secured when you hear a click.)
9. Reconnect the power and turn on the unit.

Annual Maintenance

Repeat steps 1 to 5 from the previous section and continue with the following steps:

1. Clean the HRV and ERV core:

- Remove filters, Loosen the core locking bracket, Remove the core, carefully grip ends of core and pull evenly outward
- **HRV Core** > remove dust using vacuum cleaner or rinse with cold water
 - > Soak and rinse the HRV core in warm soapy water
- **ERV Core** > remove dust using vacuum cleaner

⚠ ATTENTION ⚠

- Do not use cleaning solution for the HRV/ERV core
- Do not use pressure washer on the HRV/ERV core
- Do not place the HRV/ERV core in dishwasher
- Do not use bleach or chlorine

2. Motors - Maintenance Free, permanently lubricated

3. Drain Tube and Drain Pipe - Inspect drain tube, drain pipe and “P” trap for blockage, mold or kinks. Flush with warm soapy water and replace if worn, bent or unable to clean.

4. Clean Duct Work if Required - Wipe and vacuum the duct once every year. The duct work running to and from HRV/ERV may accumulate dirt. You may wish to contact a heating / ventilation company to do this.

5. Cleaning the Fans - Fans may accumulate dirt causing an imbalance and/or excessive vibration on the HRV/ERV. A reduction in the air flow may also occur. In new construction this may result within the first year due to heavy dust and may occur periodically after that over time depending on the outdoor conditions.

- open the service door
- remove the core
- disconnect the fan motor wires
- remove the screws securing fan assembly
- pull the fan assembly out of unit
- check for any accumulation on the blades
- clean with a small brush if necessary:
 - scrub individual fan blades until clean
 - vacuum and wipe
- put the components back in place
- reconnect the power supply and turn the unit back on.

⚠ WARNING ⚠

Electrical shock hazard. Can cause injury or death. Before attempting to perform any service or maintenance, always disconnect the unit from its power source.

6. Cleaning airflow Sensors - Dirt/Lint may accumulate on the air-flow sensors located on supply (#1) & exhaust (#2) sides and may cause “E3” or “E5” error on wall display (review page-14). To clean sensors,





- Mark both supply and exhaust sensors position & location on the diffuser.
- Remove screws & pull out both sensors gently.
- Clean the circuit board/sensors with a lintfree cloth (Take extra care while cleaning)
- Replace both sensors on their original position & location
- Tight screws

Troubleshooting

PROBLEMS	POSSIBLE CAUSES	SOLUTION
1. Air flow is low	<ul style="list-style-type: none"> - HRV/ERV airflow improperly balanced (<i>for units without built-in Automatic Electronic Air-balancing</i>) - filter clogged - core obstructed - exterior fresh air supply blocked - ductwork is restricting - power supply low (Low Voltage) 	<ul style="list-style-type: none"> - have professional balancer or contractor balance the unit - remove and clean filter - remove and clean core - remove and clean the blockage - inspect duct installation - switch off the unit immediately and call the electrician to check the voltage
2. Senses cold air from Supply	<ul style="list-style-type: none"> - Exhaust hood outside the house is blocked - HRV/ERV airflow improperly balanced (<i>for units without built-in Automatic Electronic Air-balancing</i>) - outdoor temperature is extremely cold 	<ul style="list-style-type: none"> - remove the blockage and clean the hood - have professional balancer or contractor balance the unit - placement of furniture or closed doors is restricting the movement of air in the home - install a duct heater
3. Water in the bottom of HRV	<ul style="list-style-type: none"> - drain pans, drain tube, drain pipe and “P” trap are clogged 	<ul style="list-style-type: none"> - check for blockage and for kinks in line - check connections - make sure water drains properly

PROBLEMS	POSSIBLE CAUSES	SOLUTION
<p>4. "Wall Mount Unit" showing error Codes:</p> <ul style="list-style-type: none"> - Error Code "E1" - Error Code "E2" - Error Code "E3" - Error Code "E4" - Error Code "E5" <p>Note:- E3 & E5 will not be displayed on non-balancing Deluxe, Superior, and Maxum units.</p>	<ul style="list-style-type: none"> - loss of communication with the Control Board. HRV/ERV switched to OFF mode automatically. - defrosting Temperature Sensor Failure. Blinks with the current operational display. HRV/ERV does not perform defrost cycles. - airflow Sensor Failure. Blinks with the current operational display. HRV runs at fixed default Low and High fans speeds. - Humidity Sensor Failure. Blinks with the current operational display. HRV does not run in High Humidity mode. - Kinked duct - Heavy dust built on air-flow sensors - Blinks with the current operational display. HRV/ ERV stops fans, closes damper & opens furnace/fan-coil/ heat pump interlock relay. - Fans Failure. 	<ul style="list-style-type: none"> - check wall control connections - clean temperature sensor, if it still shows "E2" error replace temperature sensor - clean dust and reinstall, if it still shows "E3" error replace the air flow sensors.(supply / exhaust pair) - replace humidity sensor - use straight metal duct work as possible - clean both air-flow sensors - check all ducts for blockage - make sure all backdraft dampers on the unit are working fine and no screws are interfering the backdraft damper function - Replace intake fan/exhaust fan
<p>5. Timer switch 20/40/60 minute light doesn't stay on</p>	<ul style="list-style-type: none"> - loose connection - the switch may be defective 	<ul style="list-style-type: none"> - check connection - replace the timer switch
<p>6. Defrost Mode does not work</p>	<ul style="list-style-type: none"> - fresh air duct maybe frozen - HRV/ERV airflow improperly balanced <i>(for units without built-in Automatic Electronic Air-balancing)</i> - defrost damper motor maybe defective - Temp. sensor maybe defective - improper defrost cycle 	<ul style="list-style-type: none"> - check and remove the ice - have professional balancer or contractor balance the unit - replace the defrost motor - replace the temp. sensor - check defrost cycle on wall - control and reprogram
<p>7. All 3 LEDs of timer switch blinks</p>	<ul style="list-style-type: none"> - Control board reports error - lost communication with main control board 	<ul style="list-style-type: none"> - refer to problem 4. - check all wire connections on timer switch and main control board
<p>8. No display on wall - control</p>	<ul style="list-style-type: none"> - wires are shot - loose connection 	<ul style="list-style-type: none"> - check continuity and replace the wires - check connections on main controller and wall controller - replace wall - controller



- | | | | |
|---|---------------------|---|--------------------|
| HRV | | HRV, ERV (optional) | |
|  | Severe Conditions |  | Pacific Conditions |
|  | Moderate Conditions | ERV | |
|  | Dry Climate |  | High Humidity |

U.S. Department of Energy climate zones map

HRVs are recommended for colder climates.
ERVs are designed for warm-humid climates with long cooling seasons.