

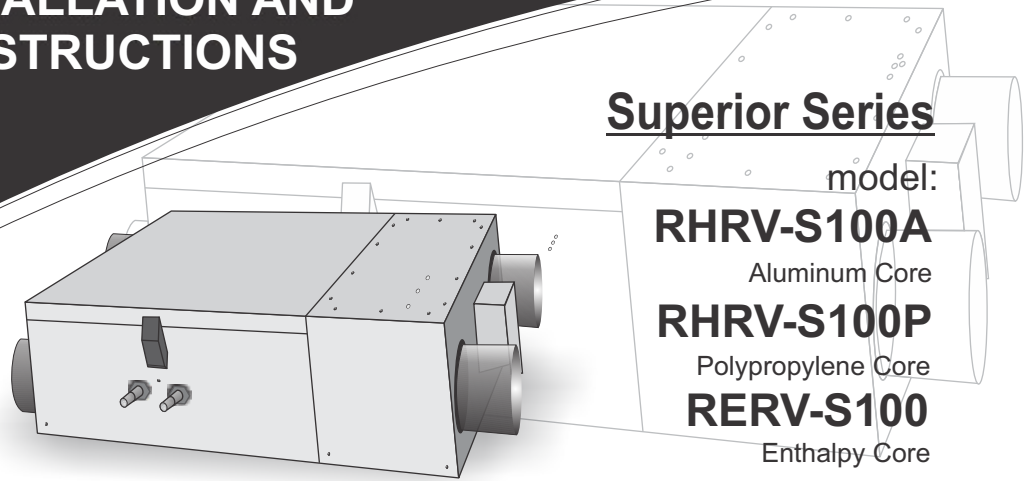

HRV / ERV INSTALLATION AND OPERATING INSTRUCTIONS



Superior Series

model:

RHRV-S100A

Aluminum Core

RHRV-S100P

Polypropylene Core

RERV-S100

Enthalpy Core



Maxum Series

model:

RHRV-S200A

Aluminum Core

RHRV-S200P

Polypropylene Core

RERV-S200

Enthalpy Core

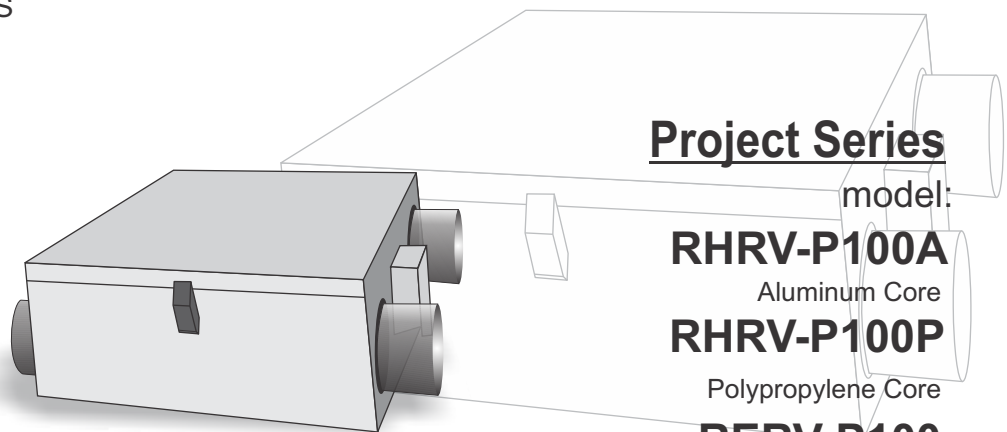

Project Series

model:

RHRV-P100A

Aluminum Core

RHRV-P100P

Polypropylene Core

RERV-P100

Enthalpy Core

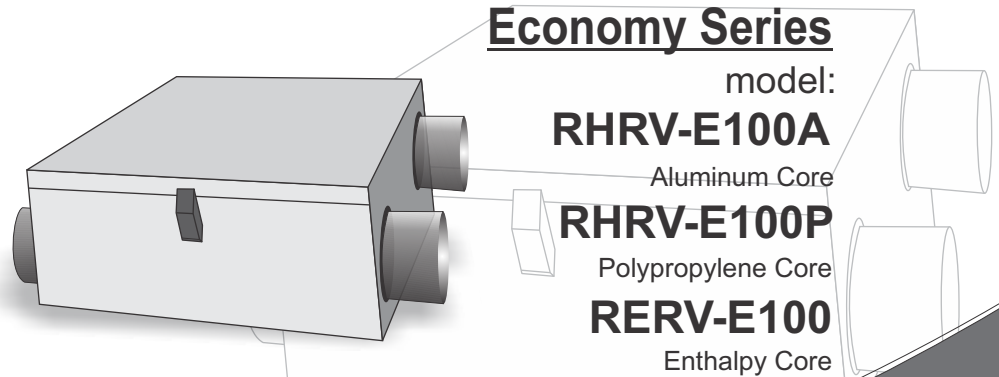

Economy Series

model:

RHRV-E100A

Aluminum Core

RHRV-E100P

Polypropylene Core

RERV-E100

Enthalpy Core

4 Pine Street
Toronto, ON Canada, M9N 2Y8
t: 416.247.0045
f: 416.247.2012

IMPORTANT SAFETY INSTRUCTIONS

READ AND SAVE THESE INSTRUCTIONS

⚠ WARNING ⚠

TO REDUCE THE RISK OF FIRE, ELECTRIC SHOCK OR INJURY, OBSERVE THE FOLLOWING:

1. Read all the instructions carefully before installation, operation or maintenance of the unit. Failure to comply with instructions could result in personal injury and/or property damage.
2. Installation of the unit and the corresponding electrical wiring must be done by a qualified person and be in accordance with all municipal and national electrical codes and pertinent industry standards should be verified before installation.
3. Use this unit only in the manner intended by the manufacturer. If you have any questions, contact the manufacturer.
4. Moving Parts, Disconnect Power supply before opening. ensure that all the nuts and screws are securely fastened before restarting the unit.
5. Before servicing or cleaning the unit, switch power off at service panel and lock the service disconnecting means to prevent power from being switched on accidentally. When the service disconnecting means cannot be locked, securely fasten a prominent warning device, such as a tag, to the service panel.
6. When cutting or drilling into wall or ceiling, make sure that you do not damage electrical wiring and other hidden utilities.
7. To reduce the risk of fire, use only metal ductwork. Do not use any accessories not recommended by the manufacturer.
8. When performing installation, servicing or cleaning these unit, it is suggested to wear safety glasses and gloves.
9. Do not use this unit for commercial purpose.
10. For residential use only. The unit must be grounded.
11. Do not install in a cooking area.
12. This unit is not designed to exhaust combustion and/or dilution air for fuel burning appliances.

⚠ CAUTION ⚠

1. Turn the unit OFF during construction or repair to avoid filter blockage.
2. Exhaust air outside - Do not intake / exhaust air into spaces within walls, crawl spaces, garage, or into attics.
3. Unit has to be installed in accordance to National and Local Building Code.
4. When leaving house for a long period of time (more than two weeks), a responsible person should check if unit operates adequately.

PACKAGING INSPECTION

Open the box and check to make sure all the parts and accessories are present and in good condition. If you find any parts missing or any shipping damage please contact factory or our distributor immediately.

CONTENTS

Parts List

- Superior Series (RHRV-S100A, RHRV-S100P, RERV-S100) 1
- Project Series (RHRV-P100A, RHRV-P100P, RERV-P100) 2
- Economy Series (RHRV-E100A, RHRV-E100P, RERV-E100) 3
- Maxum Series (RHRV-S200A, RHRV-S200P, RERV-S200) 4

Wiring Diagram

- Superior and Project Series 5
- Furnace / Fan-Coil / Heat Pump Interlock 6
 - Standard Furnace Interlock Wiring
 - Alternate Furnace Interlock Wiring

HRV and ERV Typical Installations

- For Houses 7
 - Fully Ducted System
 - Furnace Return Air-duct connection
 - Semi Ducted System
- For High Rise Condominium 7
 - Fully Ducted System
 - With Fan-Coil System
- Horizontal 8
- Vertical 8
- Access Door Installation 9
- Drain Connection 9

Air Flow Balancing

- Balancing Procedure10
- Pitot Tube Air Flow Balancing10

Maintenance

- Regular Maintenance 11
- Annual Maintenance 12

Troubleshooting

- 12

Climate Zone

- 14



Superior Series

model:

RHRV-S100A

Aluminum Core

RHRV-S100P

Polypropylene Core

RERV-S100

Enthalpy Core

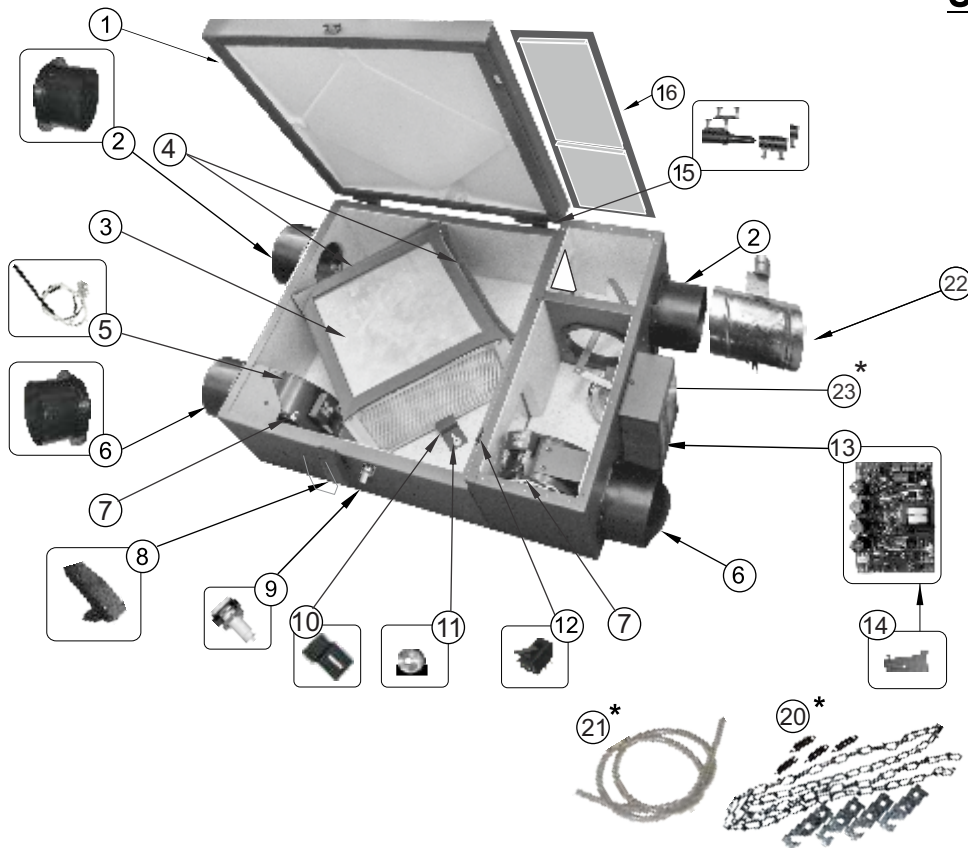

***Optional Parts:**



Reference	Description	Part no.	RHRV-S100A	RHRV-S100P	RERV-S100
			QTY.	QTY.	QTY.
1	HRV / ERV - Lid, Pan Assembly	9315	1	1	1
2	Polypropylene Collar 5" Dia.	014043C	2	2	2
3	Aluminum Core	9312	1	n/a	n/a
	Polypropylene Core	9313	n/a	1	n/a
	Enthalpy Core	9314	n/a	n/a	1
4	Filter 7" x 12" (MERV - 4)	9358	2	2	2
5	Temperature Sensor	9326	1	1	1
6	5"Ø Polypropylene Backdraft Damper	014043	2	2	2
7	Blower - Exhaust / Supply	9317	1	1	1
8	Adjustable Door Latch	9319	1	1	1
9	Drain Spout Assembly	9320	1	1	1
10	Core Locking Bracket	9321	1	1	1
11	Nut	014016	1	1	1
12	Safety Switch	9322	1	1	1
13	Main Control Board - Superior & Project	9356	1	1	1
14	Main Control Board Bracket	9355	2	2	2
15	Door Hinges	9328	1 Set	1 Set	1Set
16	Extension Box Cover	9329	1	1	1
17	Mounting Brackets	011135	4	4	4
18*	" T " Connector	9330	1	1	1
19*	Webbing/Brackets/Ladder Locks	9332	2 Sets	2 Sets	2 Sets
20*	Chains/Springs/Brackets	9354	1 Set	1 Set	1 Set
21*	Drain Pipe	9331	1	1	1
22*	120V Motorized spring return damper	9362	1	1	1
23*	Built-in spring return damper	9389	1	1	1

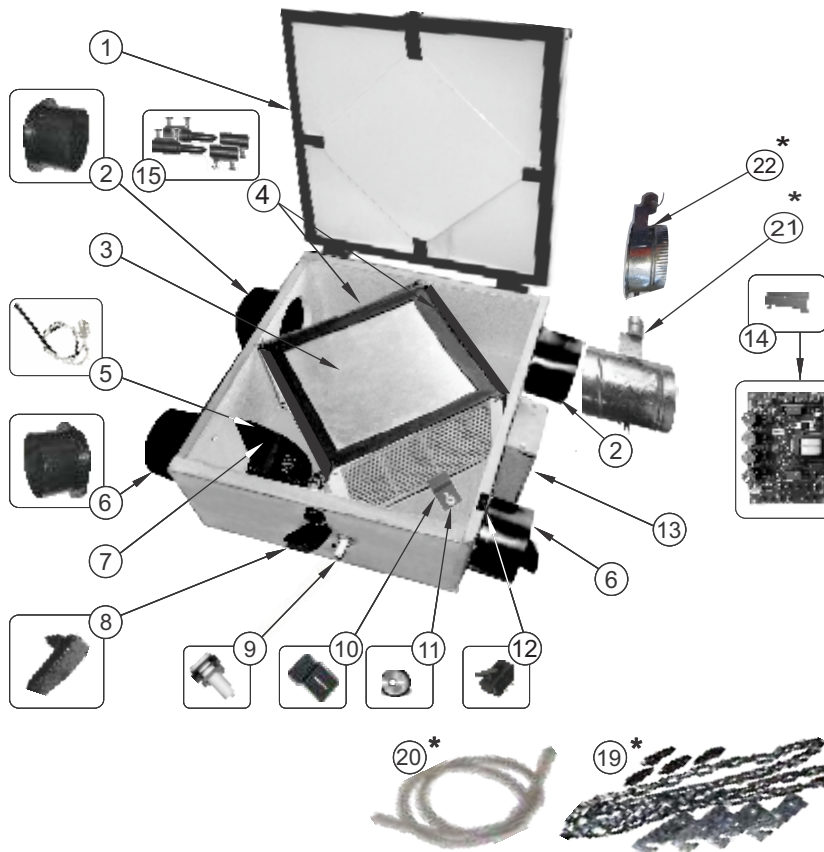

Project Series

model:
RHRV-P100A
Aluminum Core

RHRV-P100P
Polypropylene Core

RERV-P100
Enthalpy Core

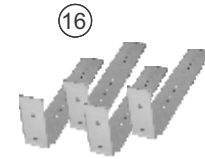

***Optional Parts:**



Reference	Description	Part no.	RHRV-P100A	RHRV-P100P	RERV-P100
			QTY.	QTY.	QTY.
1	HRV / ERV - Lid, Pan Assembly	9315	1	1	1
2	Polypropylene Collar 5" Dia.	014043C	2	2	2
3	Aluminum Core	9312	1	n/a	n/a
	Polypropylene Core	9313	n/a	1	n/a
	Enthalpy Core	9314	n/a	n/a	1
4	Filter 7" x 12" (MERV - 4)	9358	2	2	2
5	Temperature Sensor	9326	1	1	1
6	5"Ø Polypropylene Backdraft Damper	014043	2	2	2
7	Blower - Supply	9317	1	1	1
8	Adjustable Door Latch	9319	1	1	1
9	Drain Spout Assembly	9320	2	2	2
10	Core Locking Bracket	9321	1	1	1
11	Nut	014016	1	1	1
12	Safety Switch	9322	1	1	1
13	Main Control Board - Superior & Project	9356	1	1	1
14	Main Control Board Bracket	9355	2	2	2
15	Door Hinges	9328	1 Set	1 Set	1 Set
16	Mounting Brackets	011136	4	4	4
17*	" T " Connector	9330	1	1	1
18*	Webbing/Brackets/Ladder Locks	9332	2 Sets	2 Sets	2 Sets
19*	Chains/Springs/Brackets	9354	1 Set	1 Set	1 Set
20*	Drain Pipe	9331	1	1	1
21*	120V Motorized spring return damper	9362	1	1	1
22*	Built-in spring return damper	9363	1	1	1



Economy Series

model:

RHRV-E100A

Aluminum Core

RHRV-E100P

Polypropylene Core

RERV-E100

Enthalpy Core

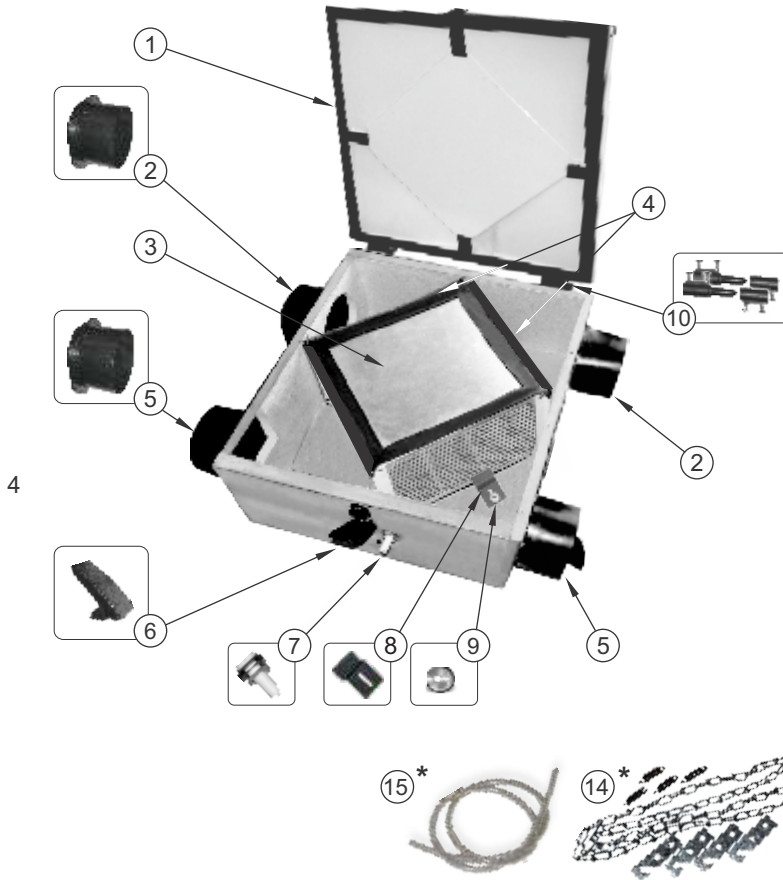

***Optional Parts:**

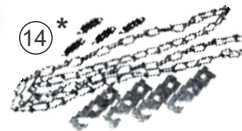

Reference	Description	Part no.	RHRV-E100A	RHRV-E100P	RERV-E100
			QTY.	QTY.	QTY.
1	HRV / ERV - Lid, Pan Assembly	9315	1	1	1
2	Polypropylene Collar 5" Dia.	014043C	2	2	2
3	Aluminum Core	9312	1	n/a	n/a
	Polypropylene Core	9313	n/a	1	n/a
	Enthalpy Core	9314	n/a	n/a	1
4	Filter 7* x 12* (MERV - 4)	9358	2	2	2
5	5"Ø Polypropylene Backdraft Damper	014043	2	2	2
6	Adjustable Door Latch	9319	1	1	1
7	Drain Spout Assembly	9320	2	2	2
8	Core Locking Bracket	9321	1	1	1
9	Nut	014016	1	1	1
10	Door Hinges	9328	1 Set	1 Set	1 Set
11	Mounting Brackets	011135	4	4	4
12*	" T " Connector	9330	1	1	1
13*	Webbing/Brackets/Ladder Locks	9332	2 Sets	2 Sets	2 Sets
14*	Chains/Springs/Brackets	9354	1 Set	1 Set	1 Set
15*	Drain Pipe	9331	1	1	1



Maxum Series

model:

RHRV-S200A

Aluminum Core

RHRV-S200P

Polypropylene Core

RERV-S200

Enthalpy Core

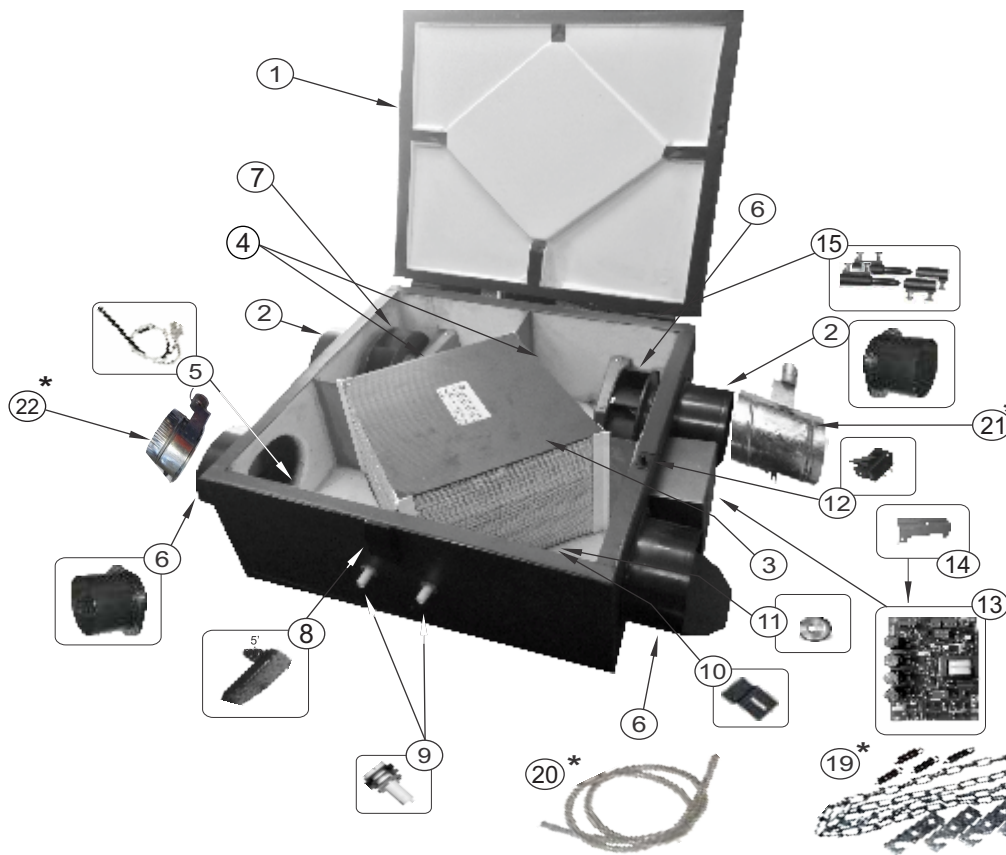

***Optional Parts:**



Reference	Description	Part no.	RHRV-P100A	RHRV-P100P	RERV-P100
			QTY.	QTY.	QTY.
1	HRV / ERV - Lid, Pan Assembly	9391	1	1	1
2	Polypropylene Collar 6" Dia.	PBD6C	2	2	2
3	Aluminum Core	9392	1	n/a	n/a
	Polypropylene Core	9393	n/a	1	n/a
	Enthalpy Core	9394	n/a	n/a	1
4	Filter 10 1/2" x 12" (MERV - 4)	9395	2	2	2
5	Temperature Sensor	9326	1	1	1
6	6"Ø Polypropylene Backdraft Damper	PBD6	2	2	2
7	Blower - Supply	013070	1	1	1
8	Adjustable Door Latch	9319	1	1	1
9	Drain Spout Assembly	9320	2	2	2
10	Core Locking Bracket	9321	1	1	1
11	Nut	014016	1	1	1
12	Safety Switch	9322	1	1	1
13	Main Control Board - Superior & Project	9356	1	1	1
14	Main Control Board Bracket	9355	2	2	2
15	Door Hinges	9328	1 Set	1 Set	1 Set
16	Mounting Brackets	011136	4	4	4
17*	" T " Connector	9330	1	1	1
18*	Webbing/Brackets/Ladder Locks	9332	2 Sets	2 Sets	2 Sets
19*	Chains/Springs/Brackets	9354	1 Set	1 Set	1 Set
20*	Drain Pipe	9331	1	1	1
21*	120V Motorized spring return damper 6"Ø	9397	1	1	1
22*	Motorized damper spring return built-in 6"Ø	9398	1	1	1



CONTROL BOARD:

Optional Accessories (Not Supplied)

- a) Timer Switch (TC100)
- b) Wall Switch
- c) Dehumidistat
- d) Time Delay Switch (TC100-120 & TC100-120P)
- e) Master On/Off Switch for HRV/ERV
- f) Light
- g) Intermittent Switch (IC 100-5V)

Note: Same power source must be used if wall switches (b) & time delay switches (d) are connected together in parallel.

Note: Up to 4 Timer Switches (TC 100-5V) and one intermittent switch (IC 100-5V) can be connected to control board of HRV/ERV by using three 24 AWG (min.) Copper wires as shown. Maximum total wire length 75ft. (see option 2)



(Also available w/o OFF mode)

Option 2:

to Control Board

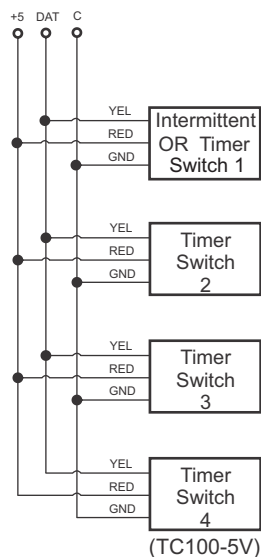

4 - Speed Controller for Manual Balancing and Air Flow Adjustment

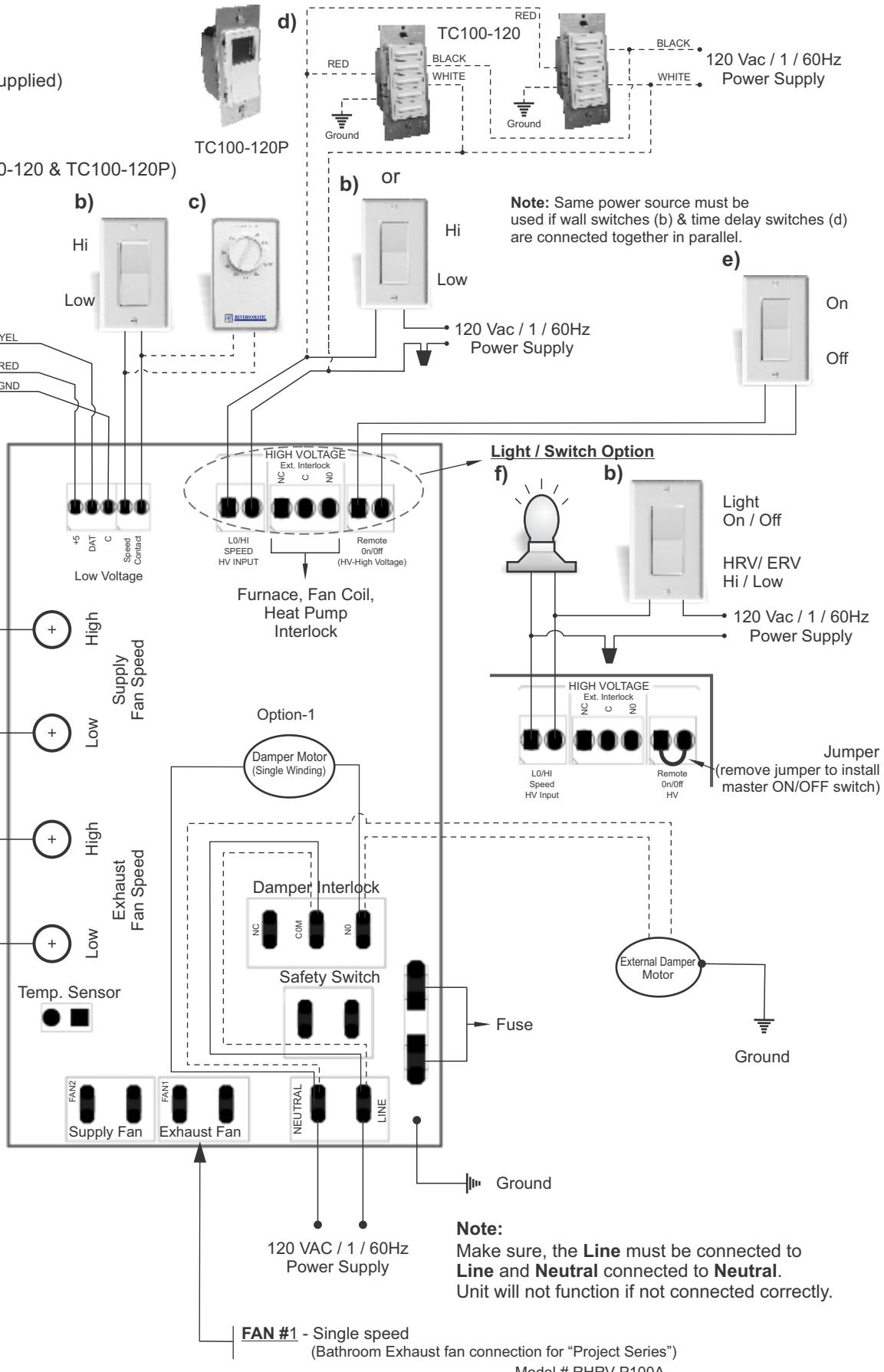

Note: Make sure, the Line must be connected to Line and Neutral connected to Neutral. Unit will not function if not connected correctly.

FAN #1 - Single speed (Bathroom Exhaust fan connection for "Project Series")

Model # RHRV-P100A
RHRV-P100P
RERV-P100

Important Note:- When installing timers or time delay switches, make sure that they are for appropriate HRV/ERV models.

Furnace / Fan-Coil / Heat Pump Interlock:

⚠ WARNING ⚠

Never connect a 120 volt AC circuit to the terminals of the furnace/fan-coil/heat pump interlock (Standard Wiring). Only use the low voltage class 2 circuit.

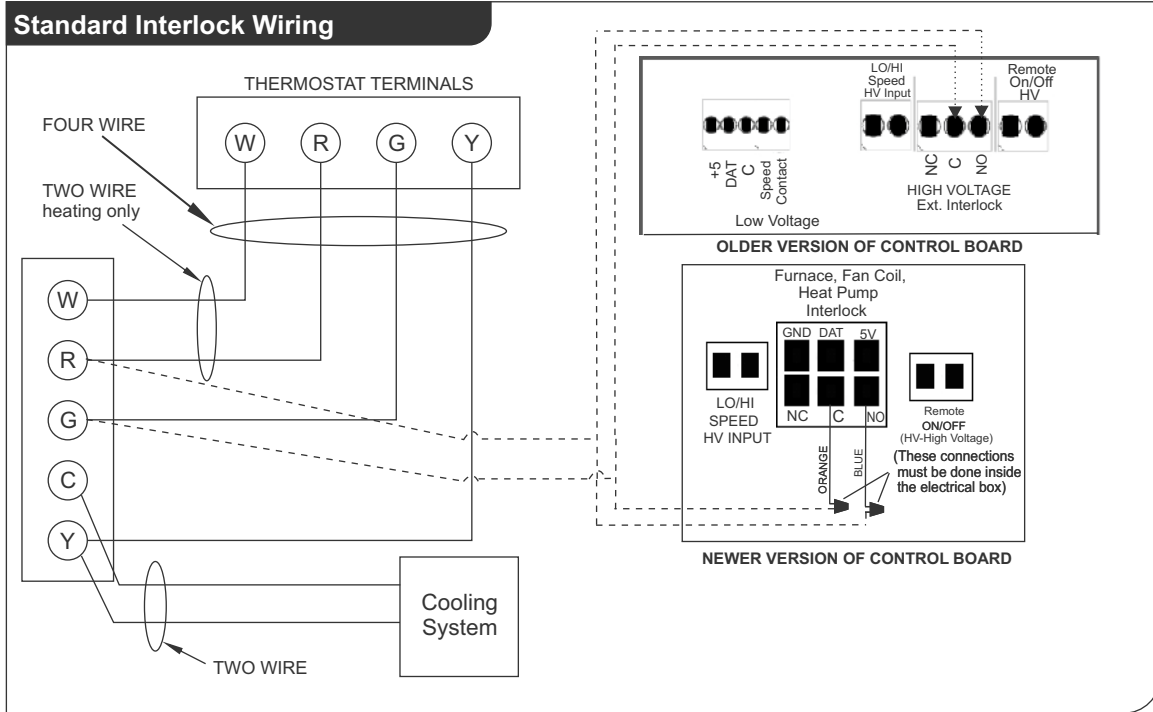

For a furnace connected to a cooling system:

On some older thermostats, energizing the R and G terminals at the furnace has the effect of energizing Y at the thermostat and thereby turning on the cooling system. If you identify this type of thermostat, you must use the "Alternate Interlock Wiring".

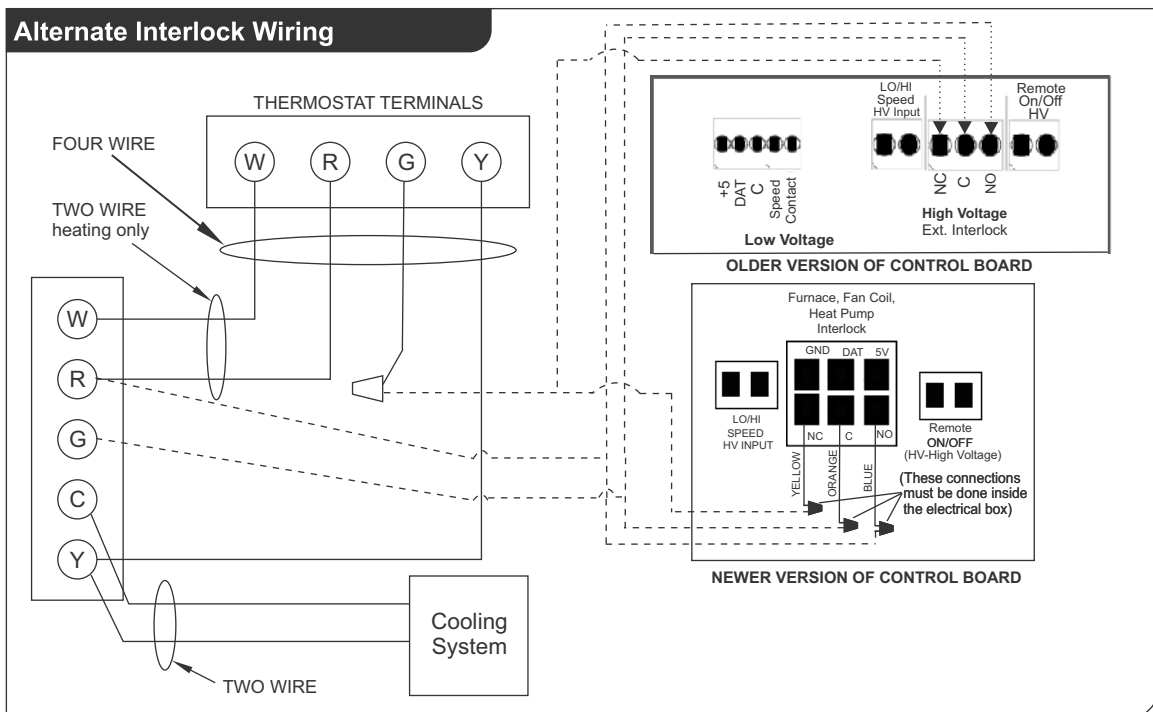



Typical Installations for House

Fully Ducted System

(for Superior & Maxum series only)

This is a stand alone HRV/ERV system which is not connected to a force air system. Stale air is drawn from key areas of the home (bathroom, kitchen) while fresh air is supplied to main living areas.

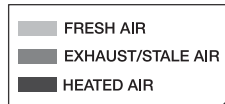

Note: (For Semi Ducted System only)

- It is recommended that the furnace blower run continuously or HRV/ERV operation be interlocked with the furnace blower to evenly distribute the fresh air throughout the house.
- A motorized backdraft damper is recommended in the fresh air supply side to prevent outdoor air entering into the system when the Furnace / Air handler fan is running and the HRV/ERV is in Standby or OFF or in defrost mode. As shown on page 6.

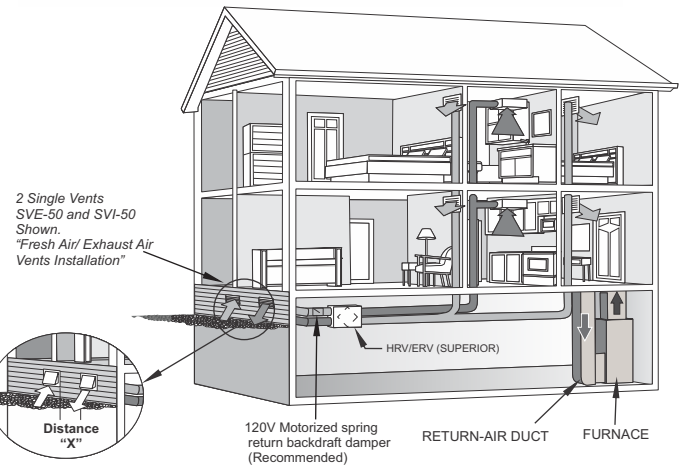

*Re - Circulation Efficiency
If distance "X" is 5ft - 99.7%
"X" is 3ft - 96.5%

Semi Ducted System (For Superior / Maxum series only)

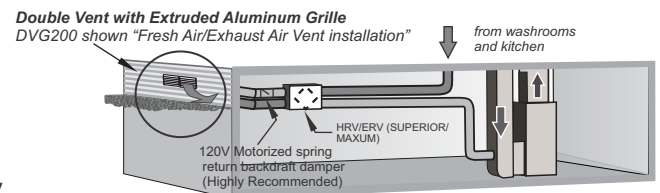

- This installation enables stale air to be drawn from the poorest air quality areas of the home (washrooms & kitchen)

Note: All Exhaust vents must be installed min. 5 ft away from sidewalls.

Installation Options for High-Rise Condominium

Superior / Maxum / Project Series Shown

Fully Ducted System

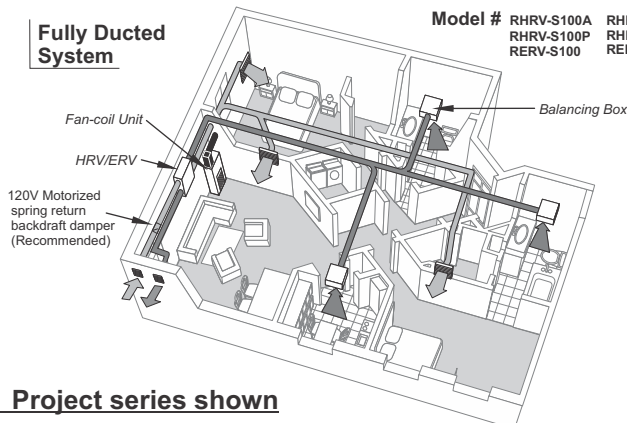

With Fan-Coil System

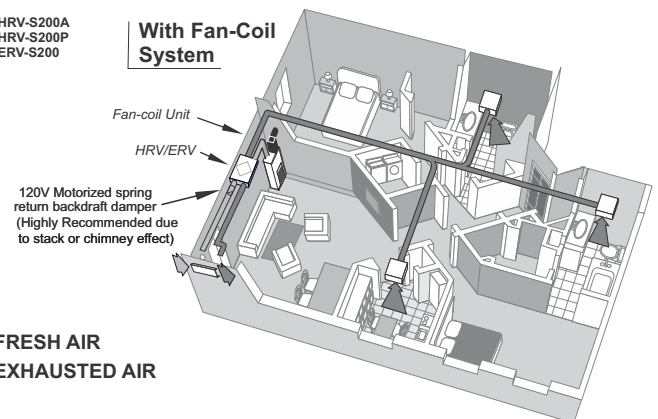

Project series shown

Fully Ducted System

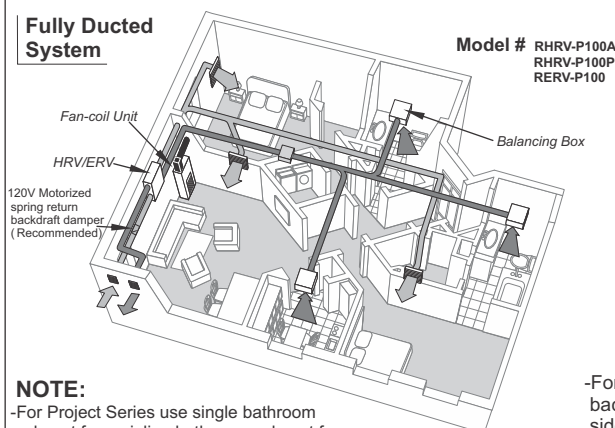

With Fan-Coil System

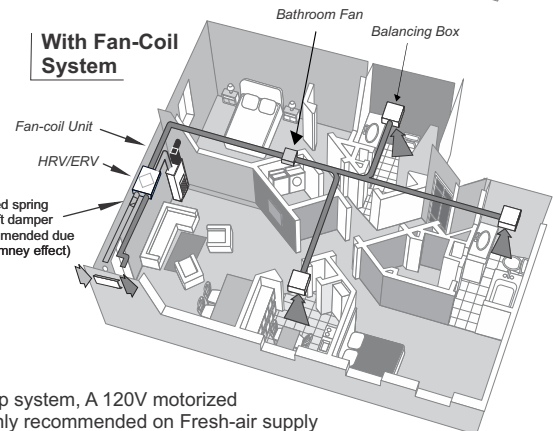

NOTE:

-For Project Series use single bathroom exhaust fan or inline bathroom exhaust fan (for two washrooms).

-For Fan-coil / Heat-pump system, A 120V motorized backdraft damper is highly recommended on Fresh-air supply side to prevent outdoor air entering into the system when the fan-coil is in OFF mode and the HRV/ERV is in OFF/standby/defrost mode and HRV/ERV must be interlocked with Fan-coil / Heat-pump.



HORIZONTAL

Note:

- 30" clearance is recommended for cleaning of the core/servicing the unit.
- Dampers are installed for horizontal installation. For vertical installation both dampers have to be turned so they can open properly and close when there is any backdraft.
- **Make sure no screw will interfere the function of the backdraft damper flaps while installing the duct work to the HRV/ERV.**

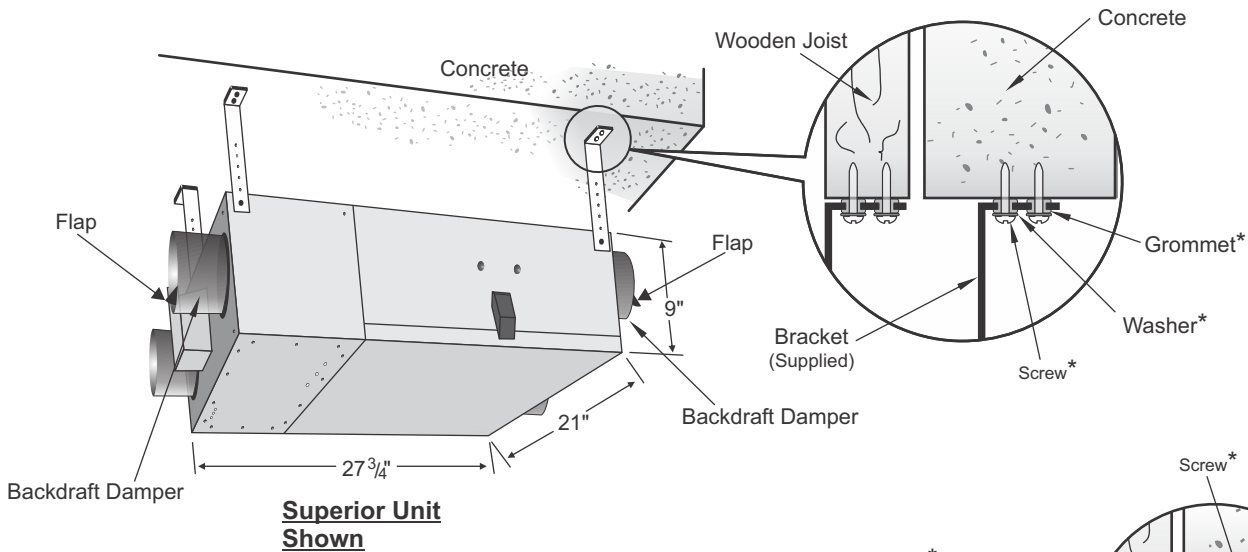

VERTICAL

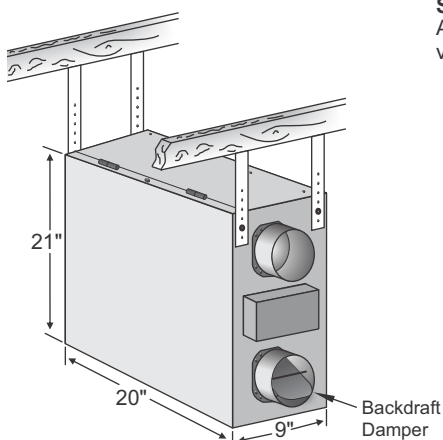

Project Condo Unit Shown

STRAPPING SYSTEM: (optional)
Allows one person installation for vertical and horizontal installation.

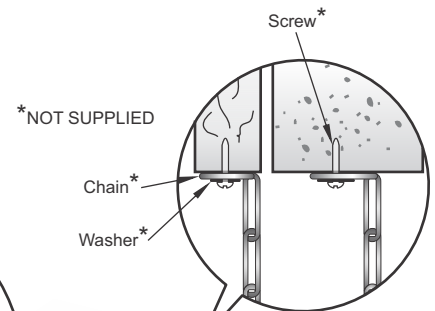
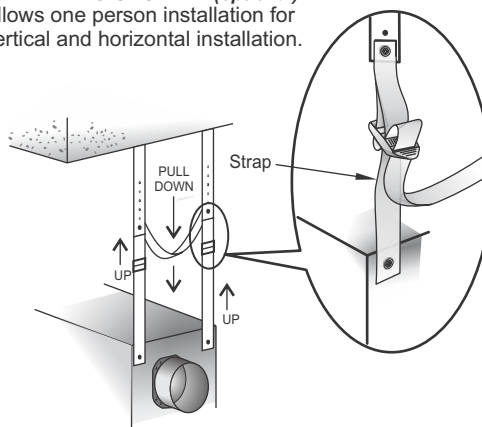

CHAIN MOUNTING SYSTEM: (optional)
Available for both horizontal & vertical installation.

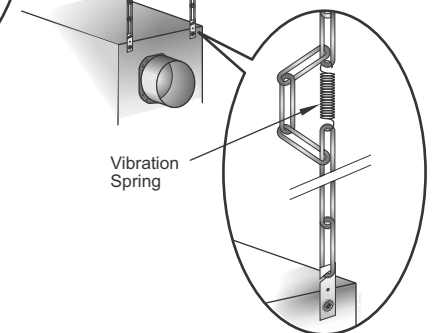

Note:

After installation make sure the HRV/ERV is properly leveled. If not levelled correctly, then defrost will not perform effectively and/or unit may frost in winter.



Typical Installations of Single Vents & Access door

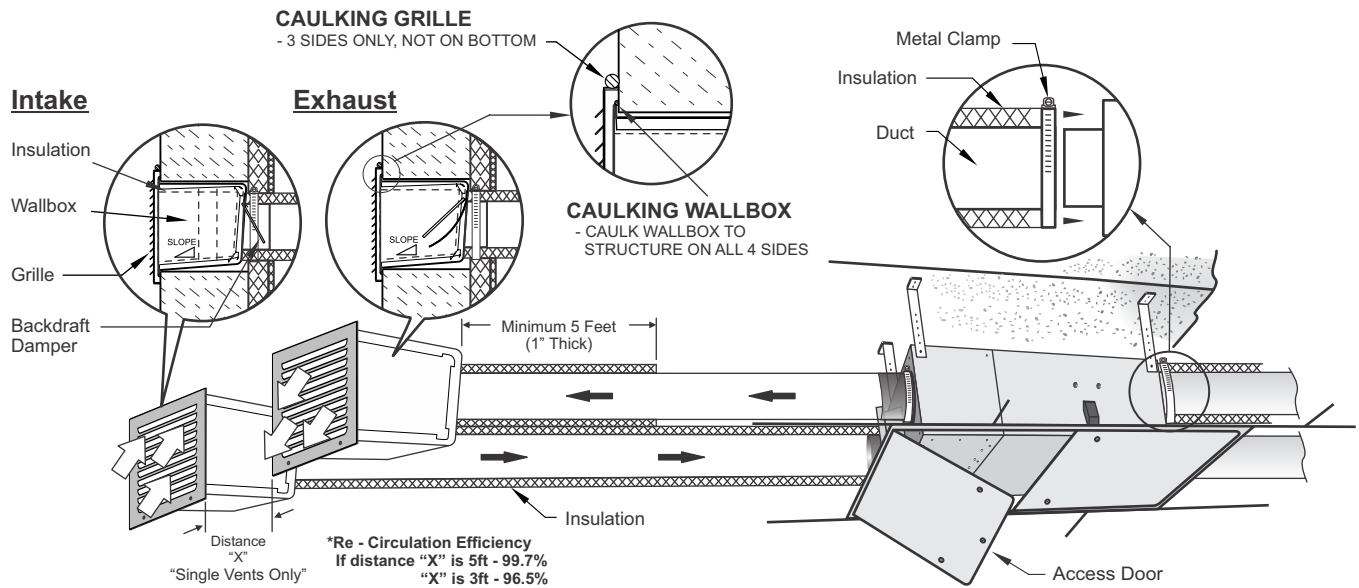

Note:
 -Fresh air intake and supply duct must be totally insulated. Exhaust duct must be 5 feet insulated. In colder climate, it is recommended to insulate all exhaust and supply ducts.

-Use appropriate access door size for easy access and routine maintenance of the unit. For more info visit <http://www.reversomatic.com/HRV&ERV/Accessories>

Drain Connection

When the outside temperature drops below -5°C , the Reversomatic HRV / ERV Supply Fan cycles ON / OFF depend on the outside temperature. The exhaust fan always operates normally at all times regardless of the outside air temperature. During defrost cycle the HRV unit may produce some condensation and the water should flow into a nearby drain.

The HRV cabinet has pre-punched holes for the drain, in order to keep the drain pan intact *hand tighten* the 2 plastic drain tube to the unit using the gasket and nuts.

For Vertical installation

Cut two sections of $\frac{1}{2}$ " drain pipe and connect the other ends to the drain tube then connect to "T" connector. Connect a drain line and create a **P-trap** to prevent the unit from unpleasant odours from drain source. Tape or fasten base to avoid any bends.

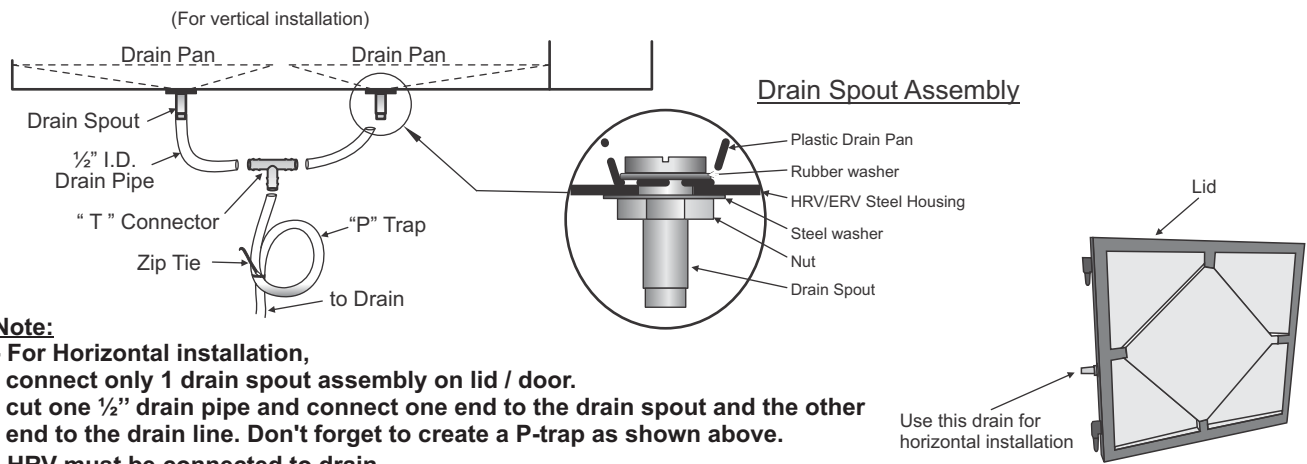

Note:
 - For Horizontal installation, connect only 1 drain spout assembly on lid / door. cut one $\frac{1}{2}$ " drain pipe and connect one end to the drain spout and the other end to the drain line. Don't forget to create a P-trap as shown above.
 - HRV must be connected to drain.
 - ERV does not required any drain. However, we recommend to connect ERV to drain in areas where extreme cold weather conditions are expected.

⚠ CAUTION ⚠

The HRV and all condensate lines must be installed in a space where the temperature is maintained above the freezing point or freeze protection must be provided.



Balancing Procedure

It is required to have balanced air flows in an HRV/ERV. The volume of air brought in from the outside must equal the volume of air exhausted by the unit while running at normal speed. If the air flows are not properly balanced, then:

- The HRV/ERV may not function at its maximum efficiency
- A negative or positive air pressure may occur in the house or condo
- The unit may not defrost properly

Prior to balancing, ensure that:

1. All the HRV/ERV's components are in place and functioning properly.
2. All sealing of the ductwork system has been completed.
3. Set the unit to normal speed.
4. Air flows in branch to specific areas of the house should be adjusted first prior to balancing the unit.
5. After taking reading of both the stale air to the HRV/ERV duct and fresh air to the house duct, the duct with the lower CFM reading should be left alone while the duct with the higher airflow should be slower down to match the lower reading by adjusting dial/speed controller on control board(see board layout on page-4). Return unit to appropriate fan speed for normal operation.

Pitot Tube Airflow Balancing

The following is a method of field balancing an HRV/ERV using a Pitot tube advantageous in situations when flow stations are not installed in the ductwork. Procedure should be performed with the HRV/ERV on normal speed.

The first step is to operate all mechanical systems on most desire speed, which have an influence on the ventilation system, i.e.the forced air furnace or air handler if applicable. This will provide the maximum pressure that the HRV/ERV will need to overcome, and allow for a more accurate balancing of the unit.

Drill a small hole in the duct (about 3/16"), three feet downstream of any elbows or bends, and one foot upstream of any elbows or bends. These are recommended distances but the actual installation may limit the amount of straight duct.

The Pitot tube should be connected to a magnehelic gauge capable of reading from 0 to 0.25 in. (0-62 Pa) or other digital airflow meter. The tube coming out of the top of the pitot is connected to the high pressure side of the gauge/meter and the tube coming out of the side of the pitot is connected to the low pressure or reference side of the gauge/meter.

Insert the pitot tube into the duct; pointing the tip into the airflow. For general balancing it is sufficient to move the pitot tube around in the duct and take an average or typical reading. Repeat this procedure in the other duct. Determine which duct has the highest airflow (highest reading on the gauge). Then slower down that motor speed by adjusting dial/speed controller on control board to match the lower reading from the other duct. The flows should now be balanced. Actual airflow can be determined from the gauge/metre reading. The value read on the gauge is called the velocity pressure and on the flow meter is called air velocity(FPM). The Pitot tube comes with a chart that will give the air flow velocity based on the velocity pressure indicated by the gauge. This velocity will be in either feet per minute or metres per second. To determine the actual airflow, the velocity is multiplied by the cross sectional area of the duct being measured.

Pitot tube and gauge

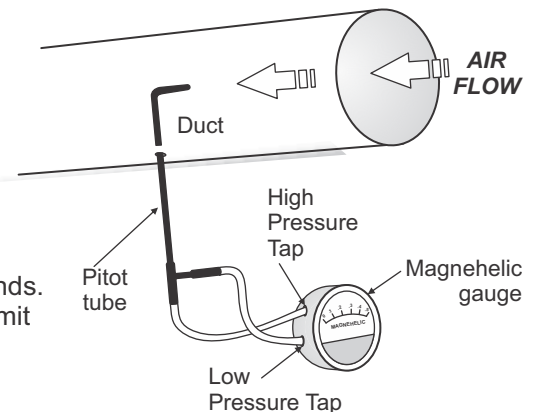

NOTE:
Place the magnehelic gauge on a level surface and adjust it to zero.



Note:(Option #2)- Only for "superior" series

- *For balancing, extension box cover plate is provided with 3 holes on supply side and 3 holes on exhaust side.
- *Do not use pitot tube to open holes in the insulation as it may block/damage the pitot tube.
- *Take 3 readings on each hole and average all 9 readings for supply and same for exhaust.
- *After finish balancing, plug all six holes with plastic plugs provided with the unit.

DUCT DIAM.	CROSS SECTION AREA
5"	0.136 sq. ft.
6"	0.196 sq. ft.

ΔP"		CFM
Ø5	Ø6	
0.010	0.004	50
0.012	0.006	60
0.016	0.008	70
0.022	0.010	80
0.027	0.013	90
0.034	0.016	100
0.041	0.020	110
0.048	0.023	120
0.057	0.027	130

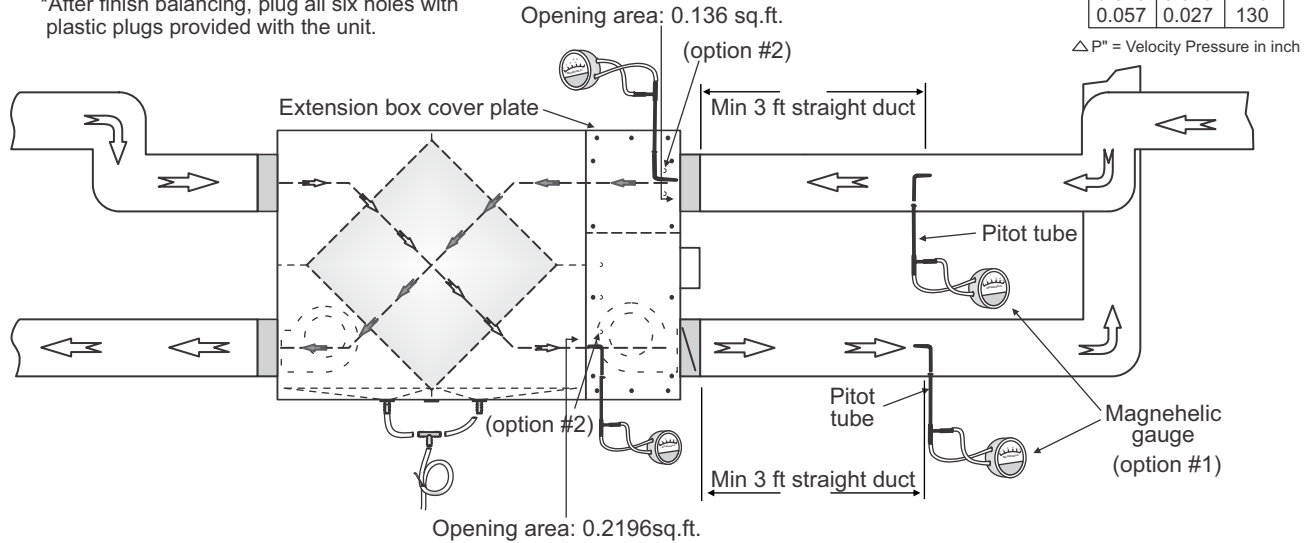

Note: To take more accurate readings, use option #1(if possible).
Project and Project Condo Units use Option #1

CFM = Opening / Cross-sectional Area(sq.ft.) x velocity(FPM)

The accuracy of the flow reading will be affected by how close to any elbows or bends the readings are taken. Accuracy can be increased by taking an average of multiple readings as outlined in the literature with the Pitot tube.

Air Flow (CFM) Chart for Different Knob Position



RERV - S100 AND RHRV - S100A/S100P					
SUPPLY (LOW SPEED / HIGH SPEED) 190 mm VENTURIES					
KNOB POSITION ↙		KNOB POSITION ←		KNOB POSITION ↖	
S.P. (IN. W.G.)	CFM	S.P. (IN. W.G.)	CFM	S.P. (IN. W.G.)	CFM
0"	55	0"	85	0"	103
0.05"	52	0.05"	83	0.05"	101
0.10"	48	0.10"	82	0.10"	99
0.15"	45	0.15"	78	0.15"	95
0.20"	42	0.20"	76	0.20"	93
0.25"	40	0.25"	74	0.25"	91
		0.30"	71	0.30"	89
		0.35"	69	0.35"	87
		0.40"	66	0.40"	85
		0.45"	63	0.45"	83
		0.50"	60	0.50"	82
KNOB POSITION ↗		KNOB POSITION ↘		KNOB POSITION →	
S.P. (IN. W.G.)	CFM	S.P. (IN. W.G.)	CFM	S.P. (IN. W.G.)	CFM
0"	122	0"	129	0"	134
0.05"	120	0.05"	128	0.05"	133
0.10"	119	0.10"	126	0.10"	132
0.15"	116	0.15"	125	0.15"	130
0.20"	114	0.20"	123	0.20"	129
0.25"	112	0.25"	122	0.25"	127
0.30"	110	0.30"	119	0.30"	125
0.35"	107	0.35"	116	0.35"	123
0.40"	104	0.40"	114	0.40"	120
0.45"	103	0.45"	112	0.45"	117
0.50"	101	0.50"	111	0.50"	115
		0.55"	109	0.55"	111
		0.60"	107	0.60"	109
		0.65"	106	0.65"	107
		0.70"	104		
		0.75"	102		



RERV - S100 AND RHRV - S100A/S100P EXHAUST (LOW SPEED / HIGH SPEED) 190 mm VENTURIES							
KNOB POSITION ↻		KNOB POSITION ←↻		KNOB POSITION ↻		KNOB POSITION ↻	
S.P. (IN. W.G.)	CFM	S.P. (IN. W.G.)	CFM	S.P. (IN. W.G.)	CFM	S.P. (IN. W.G.)	CFM
0"	54	0"	82	0"	104	0"	116
0.05"	50	0.05"	81	0.05"	102	0.05"	112
0.10"	47	0.10"	78	0.10"	99	0.10"	111
0.15"	42	0.15"	76	0.15"	95	0.15"	107
0.20"	40	0.20"	74	0.20"	91	0.20"	104
0.25"	38	0.25"	71	0.25"	90	0.25"	102
		0.30"	70	0.30"	89	0.30"	101
		0.35"	69	0.35"	87	0.35"	99
		0.40"	66	0.40"	86	0.40"	97
		0.45"	63	0.45"	85	0.45"	95
		0.50"	60	0.50"	83	0.50"	93
				0.55"	81	0.55"	92
				0.60"	78	0.60"	91
				0.65"	76	0.65"	90
				0.70"	74	0.70"	87
KNOB POSITION ↻		KNOB POSITION ↻		KNOB POSITION ↻		<p>(Fig. 1)</p>	
S.P. (IN. W.G.)	CFM	S.P. (IN. W.G.)	CFM	S.P. (IN. W.G.)	CFM		
0"	125	0"	129	0"	131		
0.05"	123	0.05"	126	0.05"	127		
0.10"	120	0.10"	123	0.10"	124		
0.15"	177	0.15"	120	0.15"	122		
0.20"	116	0.20"	117	0.20"	119		
0.25"	112	0.25"	114	0.25"	116		
0.30"	111	0.30"	112	0.30"	114		
0.35"	107	0.35"	107	0.35"	111		
0.40"	106	0.40"	104	0.40"	109		
0.45"	104	0.45"	102	0.45"	106		
0.50"	102	0.50"	101	0.50"	104		
0.55"	101	0.55"	99	0.55"	101		
0.60"	99	0.60"	97	0.60"	99		
0.65"	97	0.65"	95	0.65"	97		
0.70"	95						

Note: To reduce the air flow turn the Knob counter clockwise as shown in Fig.1

Note - The following air-flow results are based on rotating the knob into clock-wise direction

Maintenance



Regular Maintenance

1. Turn the unit off and disconnect the power supply.
2. Unlatch the door and lift the door panel towards you, hold it firmly and slide it to the left.
3. Clean the inside of the *door* and *drain pan* with a damp cloth to remove dirt and debris that may be present.
4. Clean the *filters*: (twice a year)
 - Remove the filters.
 - Vacuum to remove most of the dust.
 - Wash with a mixture of warm water and mild soap. Rinse thoroughly and shake filters to remove water and let dry.
5. Oil defrost damper levers and hinges.
6. Check the exterior fresh air supply hood:
 - Make sure there are no leaves, twigs, grass, ice or snow that could be drawn into the vent.
 - Partial blocking of this air vent could cause the unit to malfunction.**
7. Reassemble the components, Filters and Door (The door is secured when you hear a click.)
8. Reconnect the power and turn on the unit.



Annual Maintenance

Repeat steps 1 to 5 from the previous section and continue with the following steps:

1. Clean the HRV and ERV core:

- Remove filters
- Loosen the core locking bracket
- Remove the core, carefully grip ends of core and pull evenly outward
- **HRV Core** > remove dust using vacuum cleaner or rinse with cold water
 - > Soak and rinse the HRV core in warm soapy water
- **ERV Core** > remove dust using vacuum cleaner

⚠ ATTENTION ⚠

- Do not use cleaning solution for the HRV/ERV core
- Do not use pressure washer on the HRV/ERV core
- Do not place the HRV/ERV core in dishwasher
- Do not use bleach or chlorine

2. Motors - Maintenance Free, permanently lubricated

3. Drain Tube and Drain Pipe - Inspect drain tube, drain pipe and “P” trap for blockage, mold or kinks. Flush with warm soapy water and replace if worn, bent or unable to clean.

4. Clean Duct Work if Required - Wipe and vacuum the duct once every year. The duct work running to and from HRV/ERV may accumulate dirt. You may wish to contact a heating / ventilation company to do this.

- ### 5. Cleaning the Fans - Fans may accumulate dirt causing an imbalance and/or excessive vibration on the HRV/ERV. A reduction in the air flow may also occur. In new construction this may result within the first year due to heavy dust and may occur periodically after that over time depending on the outdoor conditions.
- unplug the HRV/ERV
 - open the service door
 - remove the core
 - disconnect the fan motor wires
 - remove the screws securing fan assembly
 - pull the fan assembly out of unit
 - check for any accumulation on the blades
 - clean with a small brush if necessary:
 - scrub individual fan blades until clean
 - vacuum and wipe
 - put the components back in place
 - reconnect the power supply and turn the unit back on.

⚠ WARNING ⚠

Electrical shock hazard. Can cause injury or death. Before attempting to perform any service or maintenance, always disconnect the unit from its power source.

Troubleshooting



PROBLEMS	POSSIBLE CAUSES	SOLUTIONS
1. Air flow is low	<ul style="list-style-type: none"> - HRV/ERV airflow improperly balanced - filter clogged - core obstructed - exterior fresh air supply blocked - damper is closed (if supplied) - ductwork is restricting - power supply low (Low Voltage) 	<ul style="list-style-type: none"> - have professional balancer or contractor balance the unit - remove and clean filter - remove and clean core - remove and clean the blockage - check damper - inspect duct installation - switch off the unit immediately and call the electrician to check the voltage
2. Senses cold air from Supply	<ul style="list-style-type: none"> - Exhaust hood outside the building is blocked - HRV/ERV airflow improperly balanced - outdoor temperature is extremely cold 	<ul style="list-style-type: none"> - remove the blockage and clean the hood - have contractor balance the unit - placement of furniture or closed doors is restricting the movement of air in the home - install a duct heater
3. Water in the bottom of HRV	<ul style="list-style-type: none"> - drain pans, drain tube, drain pipe and “P” trap are clogged 	<ul style="list-style-type: none"> - check for blockage and for kinks in line - check connections - make sure water drains properly



4. Timer switch 20/40/60 minute light doesn't stay on	- loose connection - the switch may be defective - turn off the HRV/ERV bracker	- check connection - replace the timer switch - reset the main controller
5. Unit is not defrosting properly	- fresh air duct maybe frozen - HRV/ERV airflow improperly balanced - Temp. sensor maybe defective	- check and remove the ice - have professional balancer or contractor balance the unit - replace the Temp. sensor
6. All 3 LEDs of timer switch blinks	- Control board reports error - lost communication with main control board	- refer to problem 4. - check all wire connections on timer switch and main control board
7. LED's on the Main Control board and the remote wall mount Timer Switch will flash 0.5 second On then 2 seconds Off then repeat the cycle (1 Blink)	- Exhaust fan open circuit: a) motor burned b) fan overheated	- replace motor - call technician (if possible replace fan)
8. LED's on the Main Control board and the remote wall mount Timer Switch will flash 0.5 sec On/0.5 sec Off/0.5 sec On then 2 sec Off, then repeat the cycle (2 Blinks)	- damper obstructed - exhaust fan jam / over-current	- check backdraft damper, no screw must interfere the function of the damper - replace the fan
9. LED's on the Main Control board and the remote wall mount Timer Switch will flash 0.5 sec On/0.5 sec Off/0.5 sec On/0.5 sec Off/0.5 sec On, then 2 seconds Off, then repeat the cycle (3 Blinks)	- Supply fan open circuit: a) motor burned b) fan overheated	- replace motor - call technician (if possible replace fan)
10. LED's on the Main Control board and the remote wall mount Timer Switch will flash 0.5 sec On/0.5 sec Off/0.5 sec On/0.5 sec Off/0.5 sec On/0.5 sec Off/0.5 sec On then 2 seconds Off, then repeat the cycle (4 Blinks)	- damper obstructed - Supply Fan jam / over-current	- check back-draft damper, no screw must interfere the function of the damper - replace the fan
11. LED's on the Main Control board and the remote wall mount Timer Switch will flash: 0.5 sec On/0.5 sec Off/ 0.5 sec On/0.5 sec Off/ 0.5 sec On/0.5 sec Off/ 0.5 sec On/0.5 sec Off/ 0.5 sec On/0.5 sec Off/ 0.5 sec On, then 2 seconds Off, then repeat the cycle (5 Blinks)	- temperature sensor failure (both motors shuts off)	- replace temperature sensor

Note :- Lightning, high power surge or high frequency radio signals could cause HRV/ERV goes into safe mode (unit completely shuts off and timer switches blinks either two or four times in a raw every 2 seconds interval). If this happens, turn "off" the main power of the HRV/ERV and restart the unit. If still unit does not come on, please call service technician.

Climate Zone



Select HRV/ERV for your Climate Zone

HRVs are recommended for colder climates.

ERVs are designed for warm-humid climates with long cooling seasons.

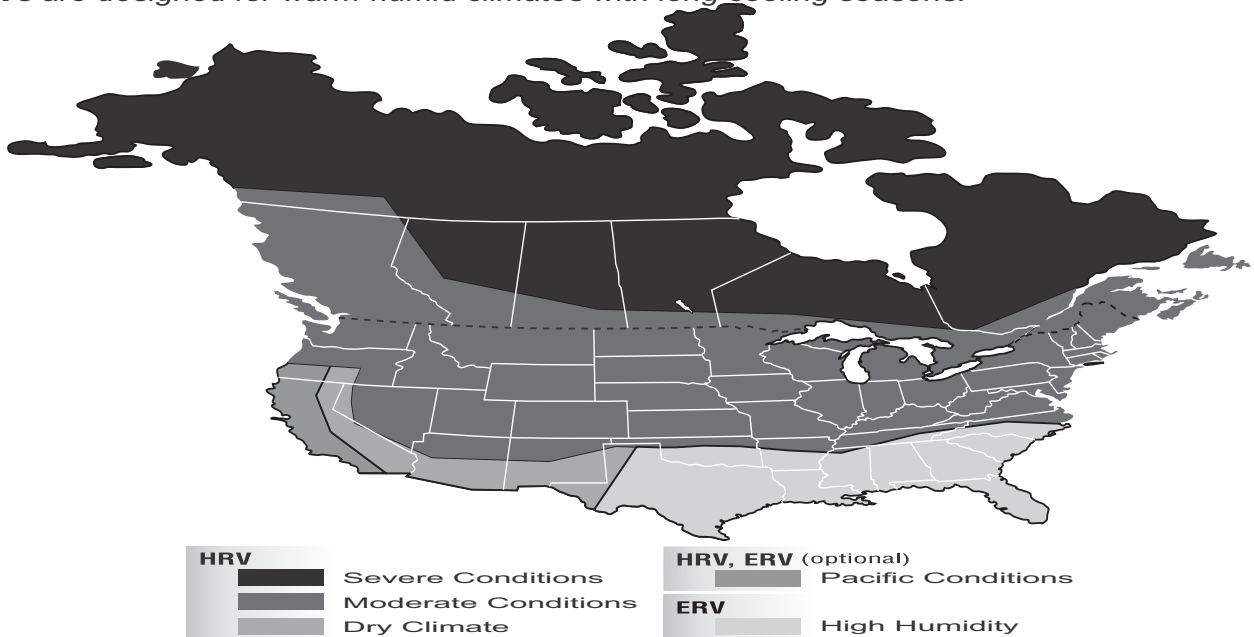

U.S. Department of Energy climate zones map

