



SWB-FL-8

DWB-FL-8

TWB-FL-8

The only wallbox in the market tested at 700 Pa to meet ASTM E-547-00, cyclic static test by EXP, an independent laboratory, which provides building envelope testing services all around the world

SINGLE WALL BOX Model: SWB-FL-8



Stamped Aluminum Grille

REVERSOMATIC BOXES are installed through all over North America in extreme cold & hot conditions including ocean front buildings & houses.

Toronto is the capital of North America for Hi-Rise condos as high as 85 stories.

Reversomatic boxes are installed in 80% of these buildings.

Available in standard sizes: 4" dia., 5" dia., 6" dia.

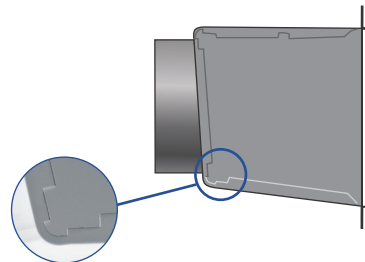

Leak Proof Seamless Flanged Wrap Construction



Optional Extruded Aluminum Grille

**TESTED FOR OCEAN FRONT • MOUNTED FLUSH WITH EXTERIOR WALL • UV PROTECTED
ENERGY EFFICIENT • ELIMINATES MOLD & MILDEW • NO LEAK GUARANTY
• SUITABLE FOR STUCCO WALL**

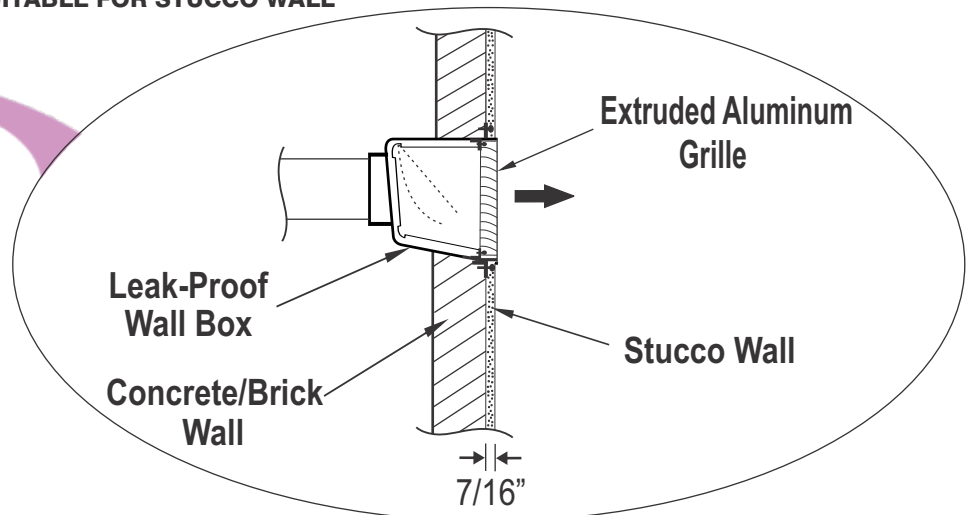



LEAK-PROOF BOXES made of 24 Ga Satin Coated Steel, Non Corrosive, rigid, very easy to install & come fully assembled. STAMPED GRILLE made of 0.025" Aluminum Alloy. EXTRUDED ALUMINUM GRILLE made of 0.050" Extruded Aluminum Alloy. All grilles are impact proof, plane aluminum or painted any colours to match with the building structure & will not discolour like some other plastic grilles in the market. NEOPRENE DAMPERS - unique patent pending tilted design provides high wind driven rain protection & prevents leakage to the interior structure.

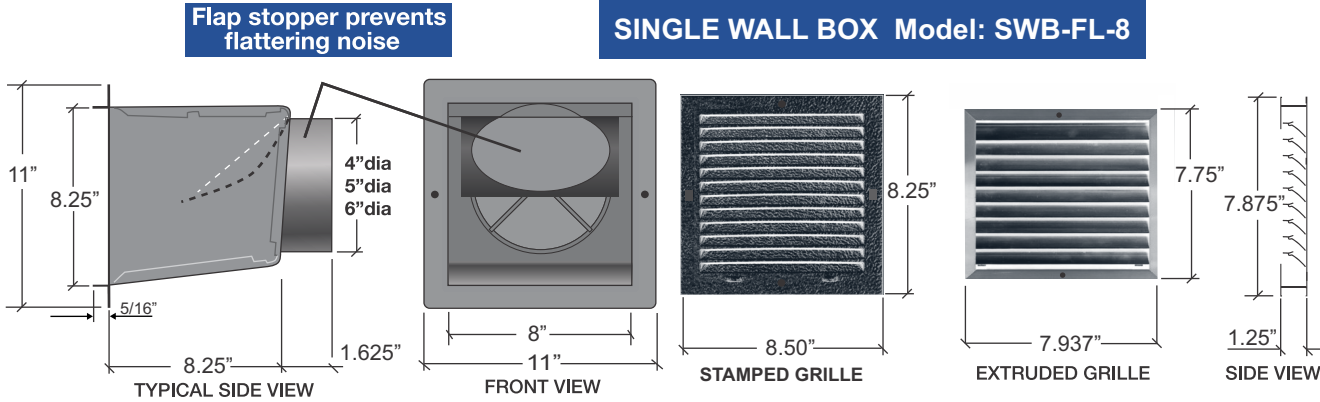

DOUBLE WALL BOX Model: DWB-FL-8

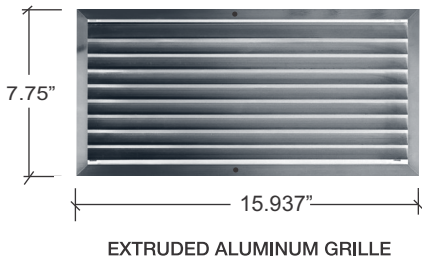
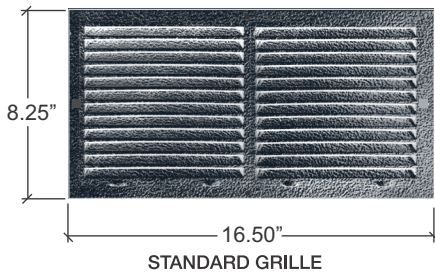
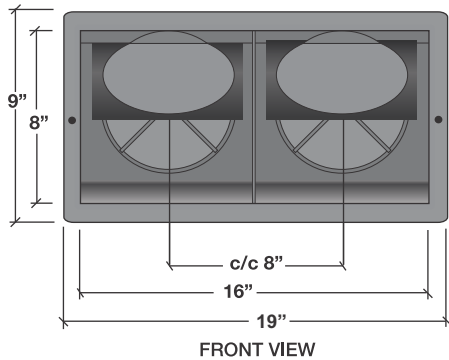

TRIPLE WALL BOX Model: TWB-FL-8

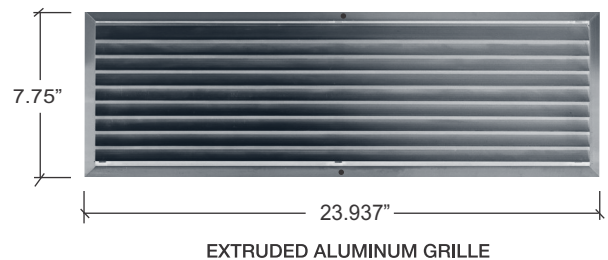
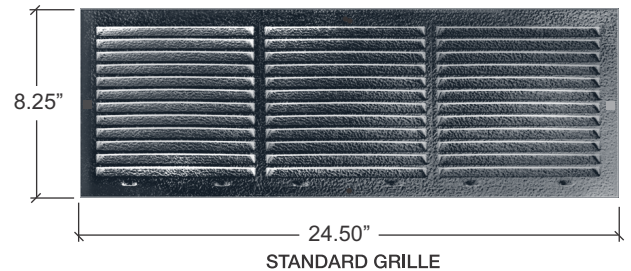
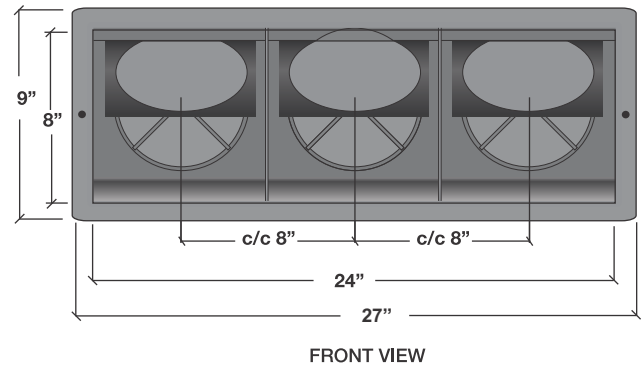

Contractor:		FLUSH MOUNT LEAK-PROOF WALL BOXES		
Architect:	Job:	Date	Supersedes	Drawing No
Engineer:	Date Submitted:	12/07/16		



VERTICAL LEAK-PROOF WALL BOXES
Suitable for Stucco Wall Installation

DWBV-FL-8

TWBV-FL-8

The only wallbox on the market tested at 700 Pa to meet ASTM E-547-00, cyclic static test by EXP, an independent laboratory, which provides building envelope testing services all around the world

VERTICAL DOUBLE WALL BOX Model: DWBV-FL-8



REVERSOMATIC BOXES are installed throughout North America in extreme cold & hot conditions including ocean front buildings & homes.

Toronto has the Largest concentration of Hi Rise Condos in North America up to 85 stories.

Vertical Double/Triple available in standard sizes: 4" dia., 5" dia., 6" dia.

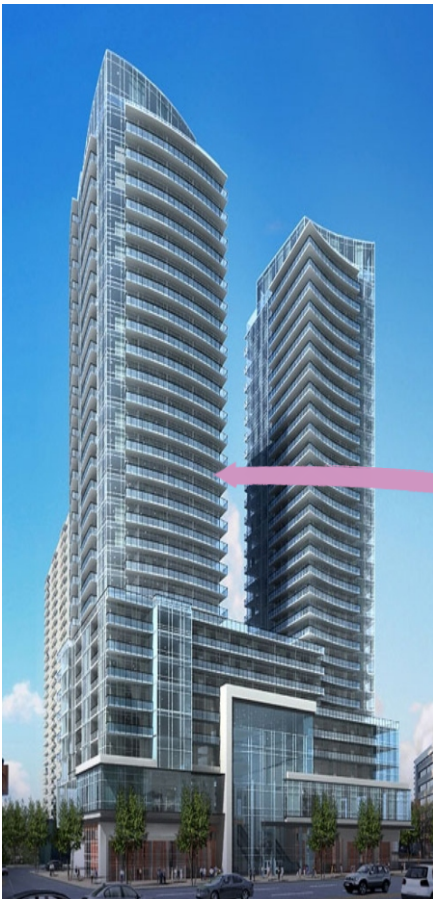

Leak Proof Seamless Flanged Wrap Construction



Optional Extruded Aluminum Grille

TESTED AND APPROVED FOR OCEAN FRONT INSTALLATION • FLUSH MOUNTED WITH EXTERIOR WALL • UV PROTECTED ENERGY EFFICIENT • ELIMINATES MOLD & MILDEW • NO LEAK GUARANTEE • SUITABLE FOR MASONRY FINISHES

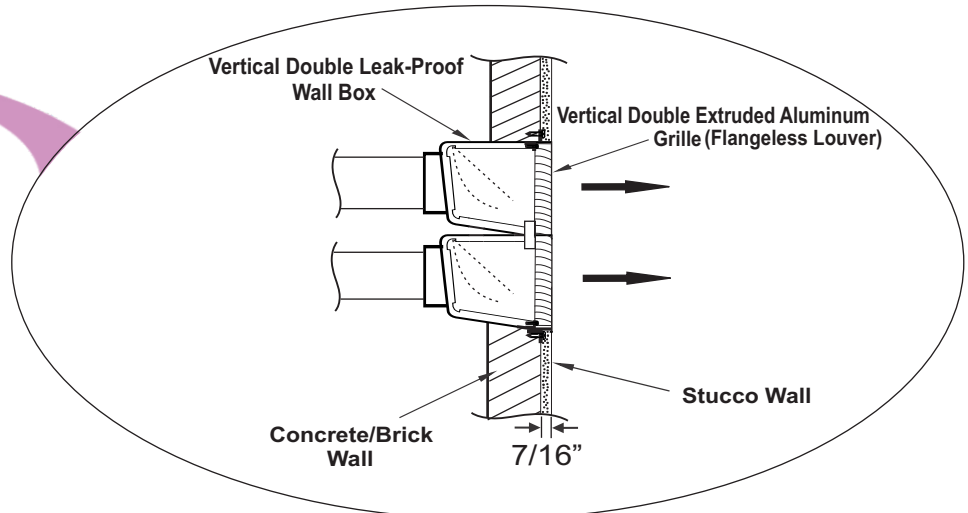



LEAK-PROOF BOXES made of 24 Ga Satin Coated Steel, Non Corrosive, rigid, very easy to install & come fully assembled. STAMPED GRILL made of 0.025" Aluminum Alloy. EXTRUDED ALUMINUM GRILLS made of 0.050" Extruded Aluminum Alloy. All grills are impact proof, plane aluminum or painted any colors to match with the building structure & will not discolor like other plastic grills in the market. NEOPRENE DAMPERS - unique patent pending tilted design provides high wind driven rain protection & prevents leakage to the interior structure.

VERTICAL DOUBLE WALL BOX Model: DWBV-FL-8

VERTICAL TRIPLE WALL BOX Model: TWBV-FL-8

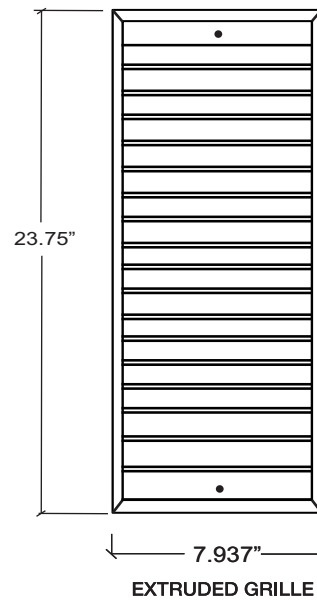
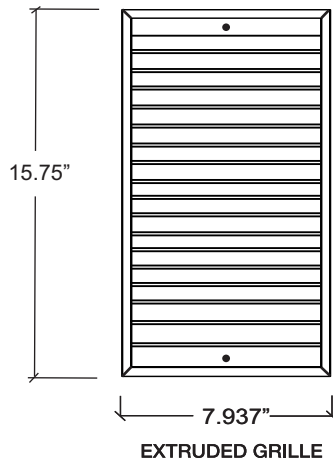
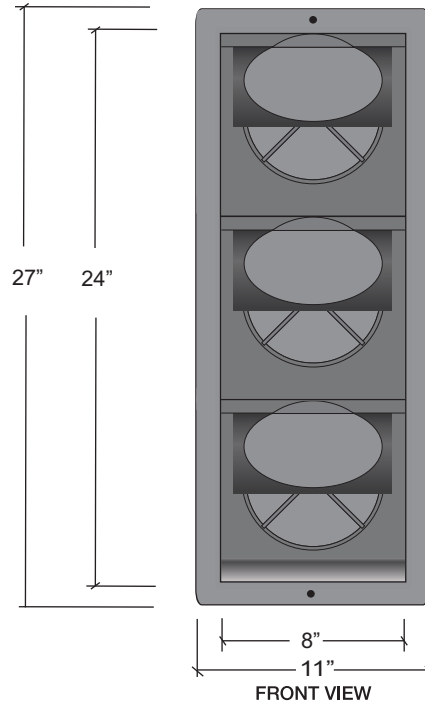
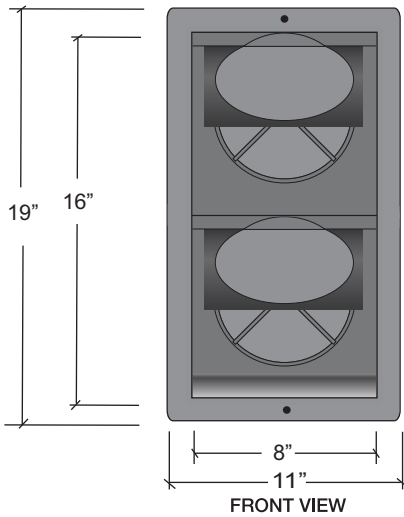

Contractor:		FLUSH MOUNT VERTICAL LEAK-PROOF WALL BOXES		
Architect:	Job:			
Engineer:	Date Submitted:	03/22/17		

Available in: 4", 5" & 6" dia. sizes

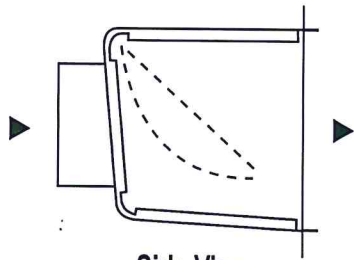

Side View
Single/Double Leak
Proof Seamless Flanged
Wrap Construction

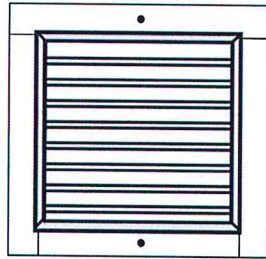

Front View
Single Extruded
Aluminum Grille

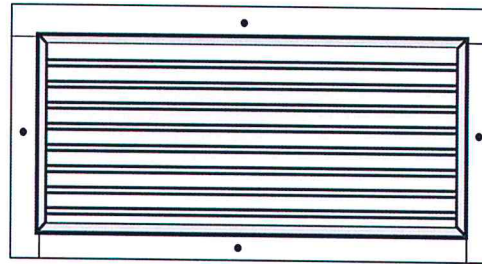

Front View
Double Extruded
Aluminum Grille

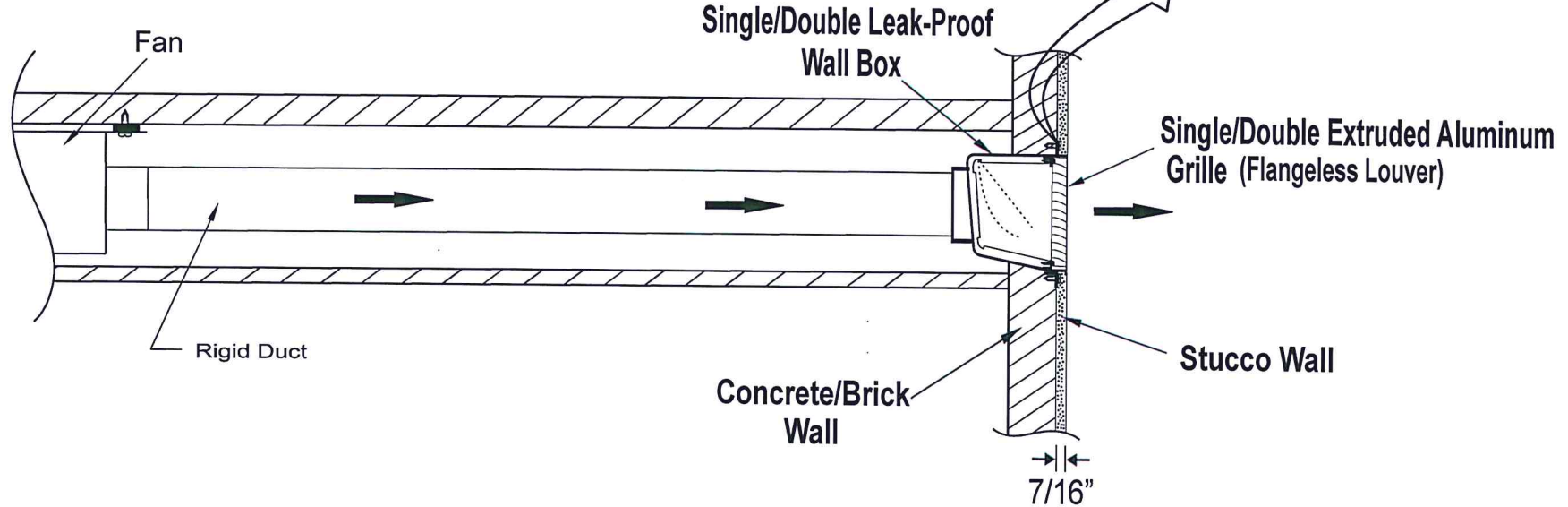
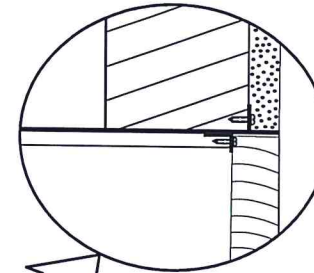

* Wind driven rain/water penetration test

Test Standard :-

Cyclic Static Test - ASTM E547-00

Static test - ASTM E331-00

Tested @ 700 Pa



REVERSOMATIC
MANUFACTURING LIMITED

790 Rowntree Dairy Road, Woodbridge, ON Canada

Tel: 905-851-6701 • Fax: 905-851-8376

www.reversomatic.com

U.S.A. Sales Office & Warehouse

2555 Porter Lake Drive, Suite 103

Sarasota, FL 34240

Tel: 941-870-2320 Fax: 941-870-0652

TITLE: TYPICAL FLUSH MOUNT LEAKPROOF SINGLE & DOUBLE WALL BOX
INSTALLATION WITH FLANGELESS EXTRUDED ALUMINUM GRILLE

REVISION	DATE	DRAWN BY:
	03/08/17	APPROVED BY:
		DATE:
		SCALE: NTS
		DRAWING NO:

Available in: 4", 5" & 6" dia. sizes

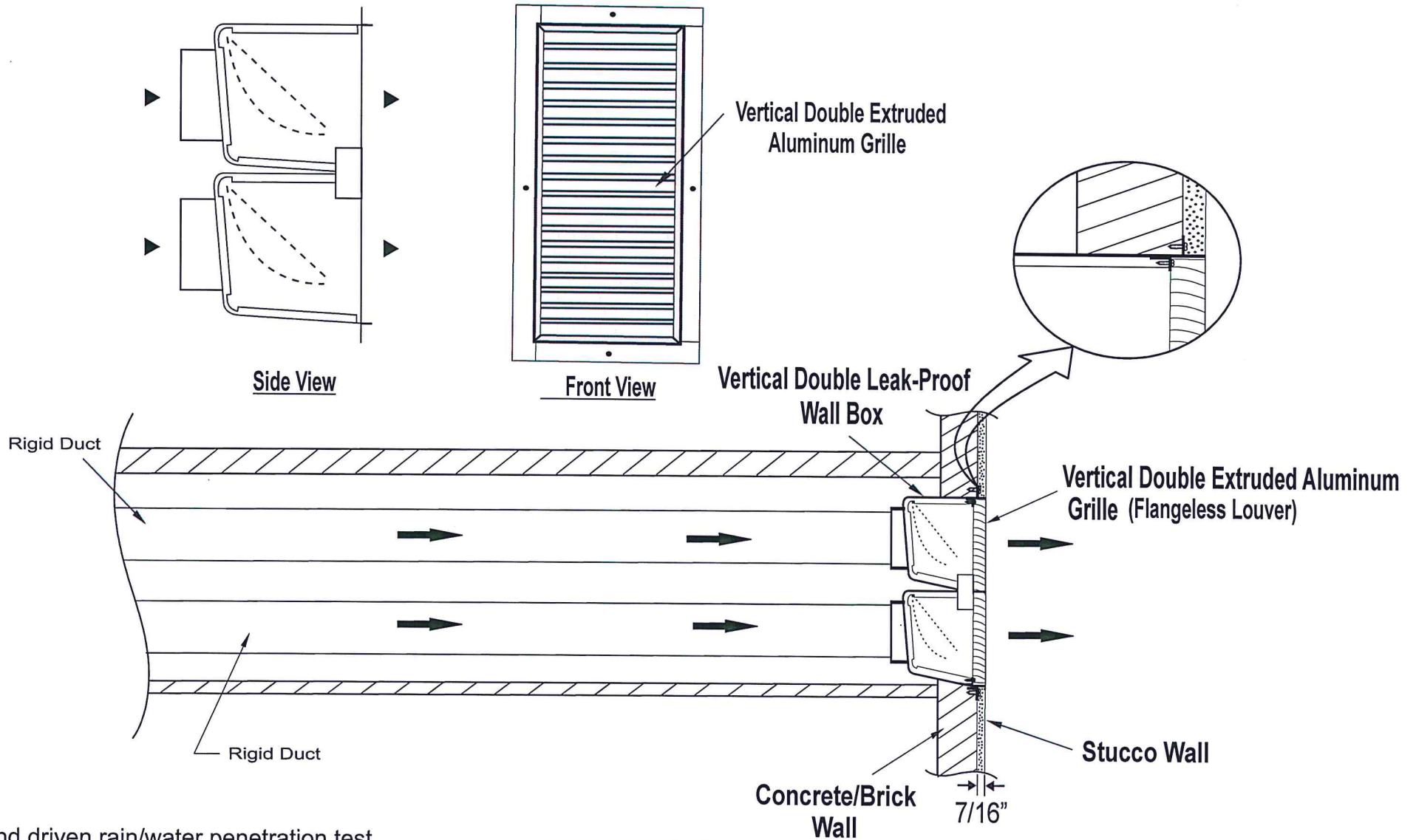

* Wind driven rain/water penetration test

Test Standard :-

Cyclic Static Test - ASTM E547-00

Static test - ASTM E331-00

Tested @ 700 Pa



REVERSOMATIC
MANUFACTURING LIMITED

790 Rowntree Dairy Road, Woodbridge, ON Canada

Tel: 905-851-6701 • Fax: 905-851-8376

www.reversomatic.com

U.S.A. Sales Office & Warehouse

2555 Porter Lake Drive, Suite 103

Sarasota, FL 34240

Tel: 941-870-2320 Fax: 941-870-0652

TITLE: TYPICAL FLUSH MOUNT LEAKPROOF VERTICAL DOUBLE WALL BOX
INSTALLATION WITH FLANGELESS EXTRUDED ALUMINUM GRILLE

REVISION	DATE	DRAWN BY:
	03/09/17	APPROVED BY:
		DATE:
		SCALE: NTS
		DRAWING NO: