

MAXUM

RHRV-S200A

MAXUM SERIES (Aluminum Core)

Features

- Over all size 23" (W) x 23" (D) x 12.125" (H)
- Power ratings: 115V / 1 / 60 Hz, 1.5 Amp., Standby current is 7W only
- Washable Aluminum core and Filters
- High efficiency energy saving permanently lubricated variable speed PSC motors for air balancing
- Suitable for horizontal & vertical installation
- **Tilted core design for maximum efficiency**
- Automatic fan cycled defrost
- Exhaust up to four washrooms
- Suitable for Corridor
- Two Speed exhaust (High / Low) - up to 225 CFM maximum
- Continuous fresh air supply at Normal speed up to 150 CFM
- Furnace / Fan-coil / Heat Pump Interlock
- Dual Protection: If exhaust fan fails, the outside fresh-air supply will be closed by shutting off supply motor and the relay contact for motorized damper and interlock will be opened. Fan Coil/Furnace low speed will be stopped and at normal operation no air will enter into the system
- In case of power failure, optional motorized spring return damper stops the fresh air intake and prevent core from freezing
- Weight approximately 52 lbs., 2 years warranty on parts

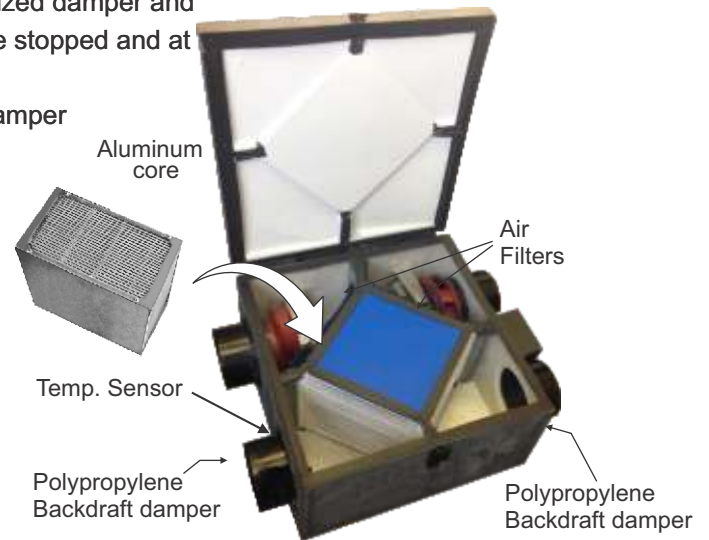
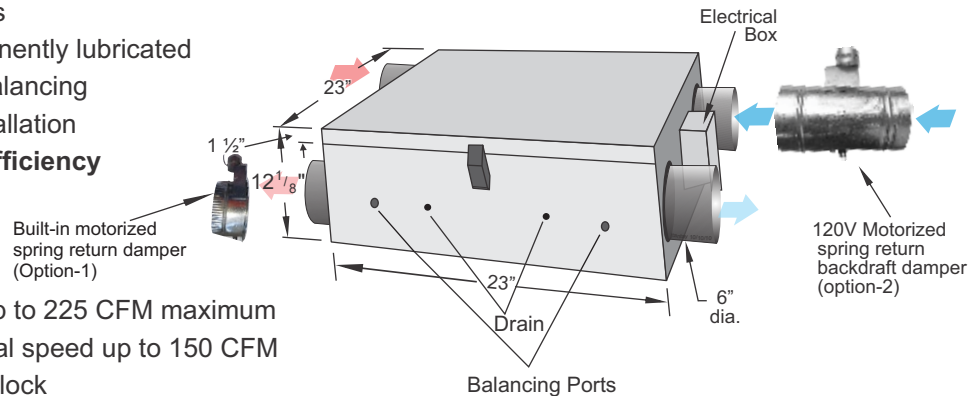

Accessories (Included):

- Mounting brackets and Drain plugs

Optional:

- Motorized Damper (120V AC), option 1 & 2
- Dehumidistat
- Pipe and "T" connector
- Time Delay Switch (120V AC)
- 2 sets (Webbing/Brackets/Ladder lock)
- Intermittent Switch (5VDC)
- Push button timer switch (20/40/60 Min., 5VDC)

Installation Options for house

Furnace Return Air-duct Connection

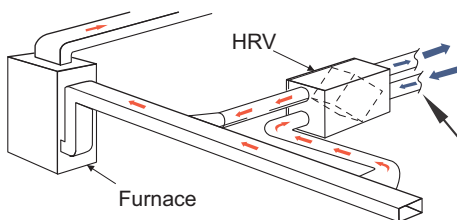

Semi Ducted System

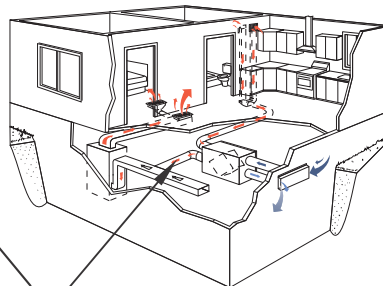

Fully Ducted System

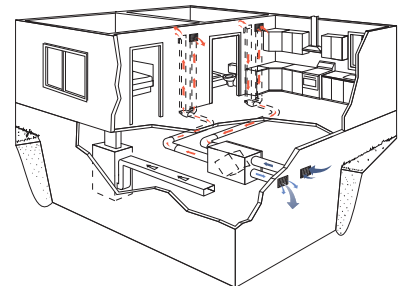

Motorized spring return damper (Highly Recommended)



Installation Options for High-Rise Condominium

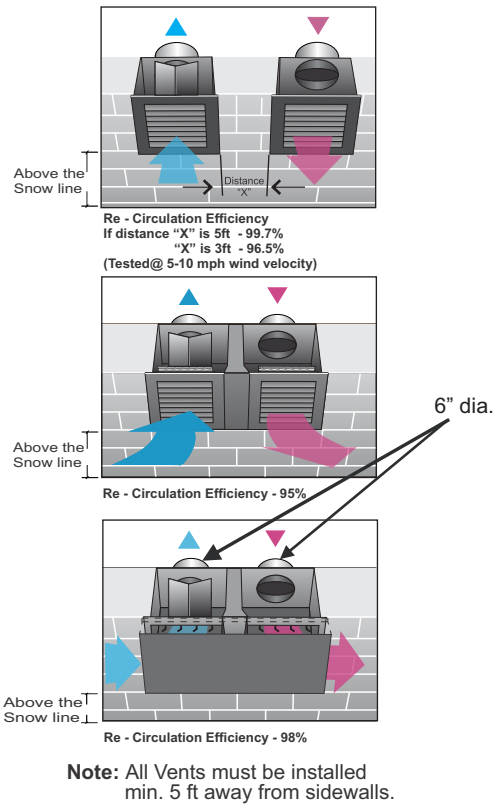

Fully Ducted System

Motorized spring return backdraft damper (Recommended)

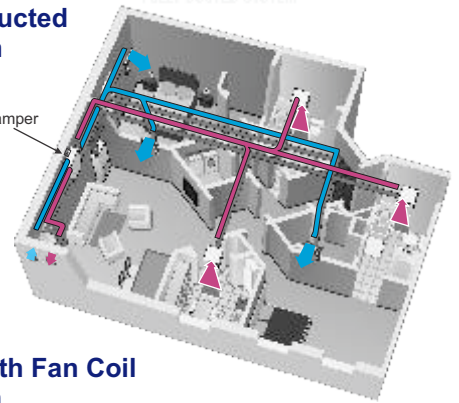

HRV with Fan Coil System

Motorized spring return backdraft damper (Highly Recommended due to chimney or stack effect)

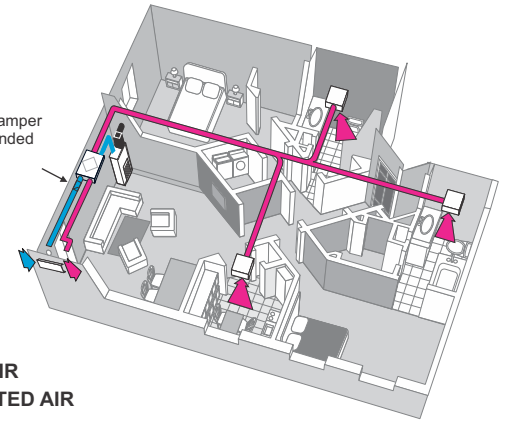

FRESH AIR
EXHAUSTED AIR

Note:

- HRV must be connected to drain.
- ERV does not required any drain. However, we recommend to connect ERV to drain in areas where extreme cold weather conditions are expected.

SOUND:

30 (L/s) @ 0.2 (IN. W.G.)	2.2 sonos (@ 50 Pa)
------------------------------	------------------------

VENTILATION PERFORMANCE

Model #	Normal Speed Supply/Exhaust (Constant Ventilation) @ 50 Pa	High Speed Exhaust (Activated by switch) @ 50 Pa	Maximum Power Rating 120V / 1 / 60Hz
RHRV-S200A	50 ~ 150 CFM variable	100 ~ 225 CFM variable	1.50 Amp.

* Normal and high speed can be adjusted by either installer or factory using speed controllers mounted on the main controller of the unit.

ENERGY PERFORMANCE

RHRV-S200A		Supply Temperature		Net Airflow		Supply / Exhaust Flow Ratio	Average Power (Watts)	Sensible Recovery Efficiency	Apparent Sensible Effectiveness	Net Moisture Transfer
		°C	°F	L/S	CFM					
Heating	i	0	32	30	63	1.01	76	69	84	1 %
	ii	0	32	37	78	1.04	85	67	81	2 %
	iii	0	32	48	101	1.02	96	65	78	0 %
	iv	0	32	63	133	1.03	112	62	73	1 %
	v	-25	-13	30	63	0.96*	75	62	82	2 %
Cooling	vi	35	95							

* Indicates the supply/exhaust flow ratio at 22° C prior to the start of the 72 hours cold weather test

Contractor:		RHRV-S200A		
Architect:	Job:	Date	Superse.des	Drawing No.
Engineer:	Date Submitted:	08/12/22		Rev. 4