

Shop Drawing RHRV-C100A

HRV Compact Unit
(Aluminum Core)

Features

- Over all size 20" (W) x 21" (D) x 9" (H), App. weight 32 lbs.
- Power ratings: 115V/1/60 Hz, 0.70 Amp.
- Washable Aluminum Core
- High efficiency energy saving permanently lubricated variable speed PSC motors for air balancing
- Furnace / Fan-coil / Heat Pump Interlock
- Dual Protection: If the exhaust fan fails, the outside fresh-air supply will be closed by shutting off the supply motor and the relay contact for motorized damper and interlock will be opened. Fan Coil/Furnace low speed will be stopped and at normal operation no air will enter into the system
- Automatic non-recirculating defrost
- washable filters
- Tilted core design
- continuous fresh air supply up to 80 CFM
- Ideal for horizontal and vertical installation
- 4 mounting brackets and 2 drain plugs are included
- Exhaust up to two washrooms

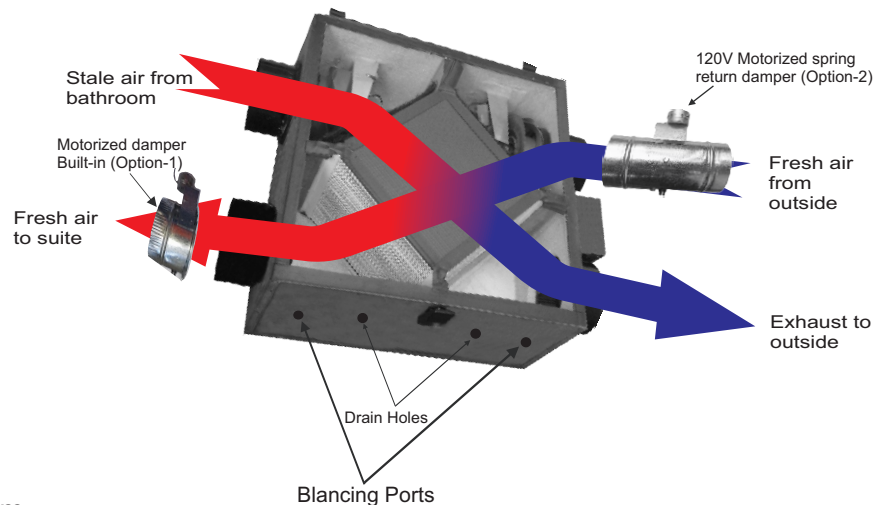
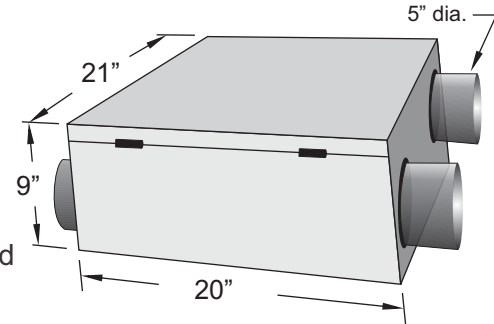

OPTIONAL ACCESSORIES:

- Push button Timer Switches (5VDC)
- Time Delay Switch (120VAC)
- Intermittent Switch (5VDC) (See on Back side)
- Dehumidistat
- Motorized spring return damper (Option 1 or 2)
- Adjustable mounting straps or chain mounting system

Fully Ducted System

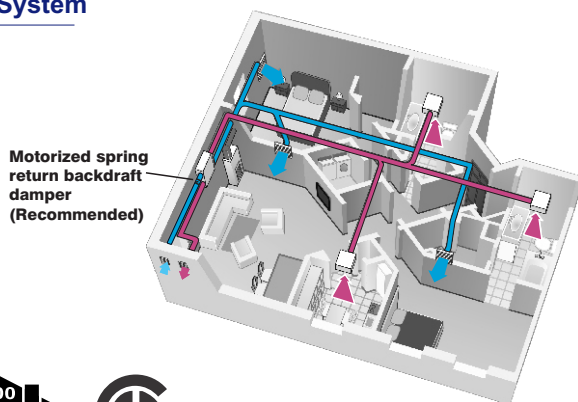

HRV with Fan Coil System

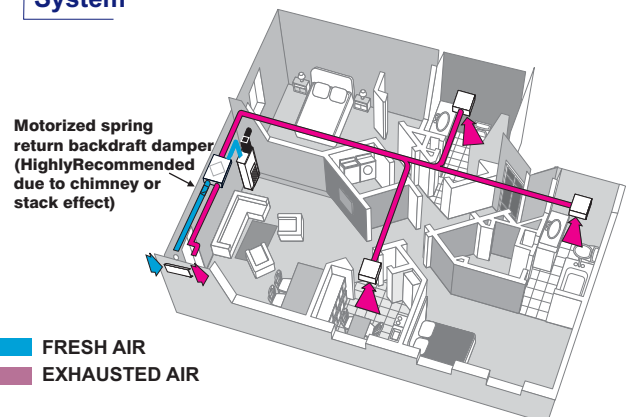

■ FRESH AIR
■ EXHAUSTED AIR



Installation Options for High-Rise Condominium

Fully Ducted System

Motorized spring return backdraft damper (Recommended)

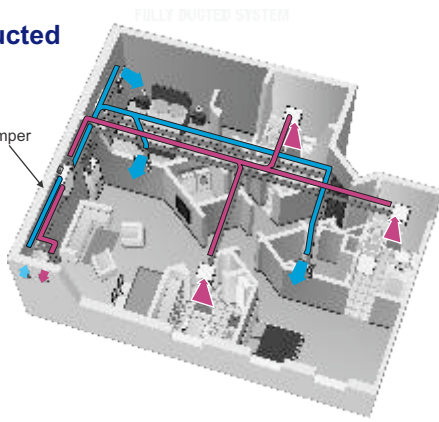

HRV with Fan Coil System

Motorized spring return backdraft damper (Highly Recommended due to chimney or stack effect)

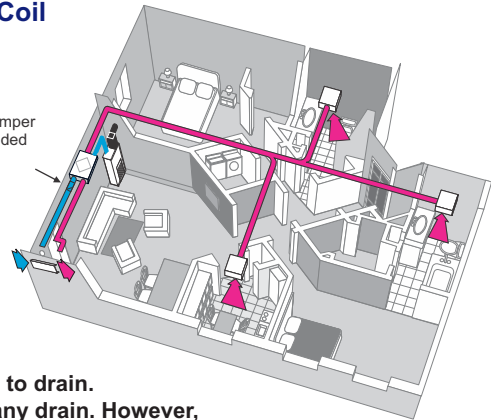

Note:

- HRV must be connected to drain.
- ERV does not required any drain. However, we recommend to connect ERV to drain in areas where extreme cold weather conditions are expected.

■ FRESH AIR
■ EXHAUSTED AIR

VENTILATION PERFORMANCE

Model #	Normal Speed Supply/Exhaust (Constant Ventilation) @ 50 Pa	High Speed Exhaust (Activated by switch) @ 50 Pa	Maximum Power Rating 120V / 1 / 60Hz
RHRV-C100A	20 ~ 80 CFM variable	70 ~ 115 CFM variable	0.70 Amp.

* Normal / High Speed and air-flow balancing can be achieved by adjusting speed controller knob located on the main controller.

ENERGY PERFORMANCE

RHRV-C100A		Supply Temperature		Net Airflow		Supply / Exhaust Flow Ratio	Average Power (Watts)	Sensible Recovery Efficiency	Apparent Sensible Effectiveness	Net Moisture Transfer
		°C	°F	L/S	CFM					
Heating	i	0	32	30	64	1.03	70	58	70	2 %
	ii	0	32	36	77	1.02	84	56	67	2 %
	iii	0	32	43	91	1.02	100	55	65	3 %
	iv	-25	-13	30	64	0.96*	75	60	72	2 %

* The Supply / Exhaust Flow Ratio at 22°C to the start of the 72 Hour Cold Weather Test

ACCESSORIES

Double Vent with Extruded Aluminum Grilles (DVG-200)
Exhaust and Intake
Optional: Stamped Aluminum Grilles

DVV-100C - Double Vent c/w Vertical Exhaust / Intake hood
(Only for Compact unit)

Double Vent with Side Exhaust / Intake (DVS-100)

Double Vent for window panel Exhaust and Intake (DV-200)

Motorized Damper
5 inch diameter spring return round damper
NSPRD024-5 (24V DC) & SPRD110-5 (110V AC)

Electronic Timer Switch (5V DC)
Activates the unit on high speed for 20, 40, 60 minutes. Suitable for Deluxe, Superior & Compact Units. (TC100)

Intermittent Switch (IC 100-5V)
Low/High/Intermittent/Off mode. In Intermittent mode, HRV/ERV runs for 20 min. in low speed & 40min. OFF. and cycles continuously.

Dehumidistat (RH100)
Wall-mount unit allows to control indoor humidity level. Suitable for Superior Series & Compact Units.

Wall Cap
Exhaust / Intake WCE-5*, WCI-5*

Access Doors
FLAT - ADF 26
PROJECT - ADP 24
DETACHABLE - ADD 24

Contractor:		RHRV-C100A		
Architect:	Job:	Date	Superse.des	Drawing No.
Engineer:	Date Submitted:	11/15/2016		

• **Softaire** •