

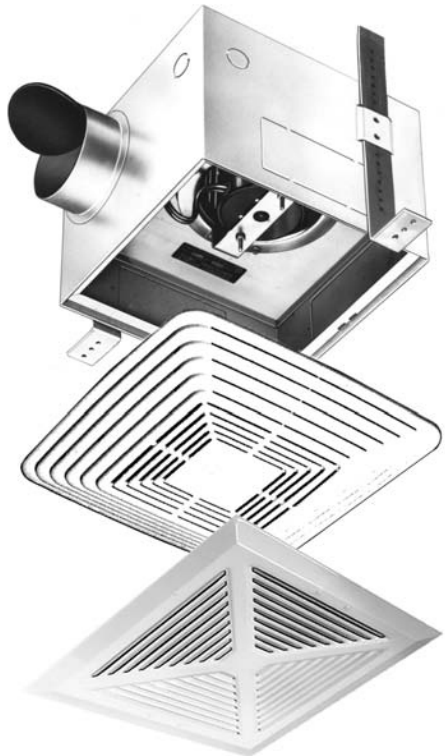

## **XL SERIES SUPER QUIET BATHROOM EXHAUST FAN**

The QB-80 fan is specially designed for bathrooms in apartments where exceptionally low noise level is required. It is available with mounting brackets for easy installation. The QB-80 is constructed of corrosion resistant heavy gauge satin coat steel. The fan is certified by California Energy Commission in accordance with California Law - Title 20. It also meets Washington State Ventilation and Indoor Air Quality Code.



Plastic Backdraft Damper

High Impact Styrene Grille

White Aluminum Louvered Grille

### **FAN DATA**

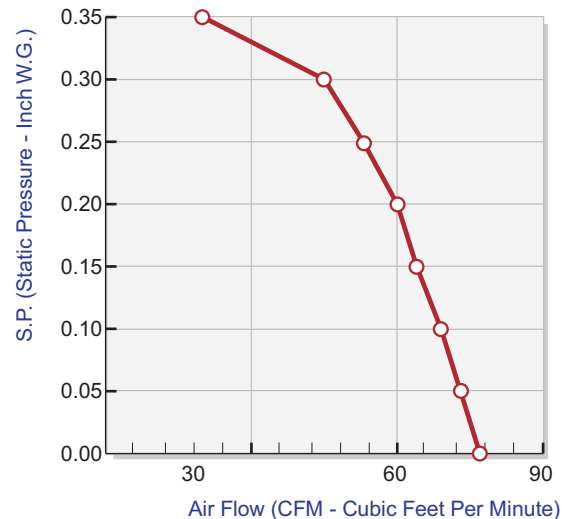

### **ACCESSORIES**

#### *Standard:*

- Plastic snap-in grille
- Mounting brackets
- Metal collar with neoprene damper

#### *Optional:*

- Variable speed control
- Aluminum backdraft damper
- Plastic backdraft damper
- Off white aluminum louvered grille
- Baffle
- Balance box
- Inline transition

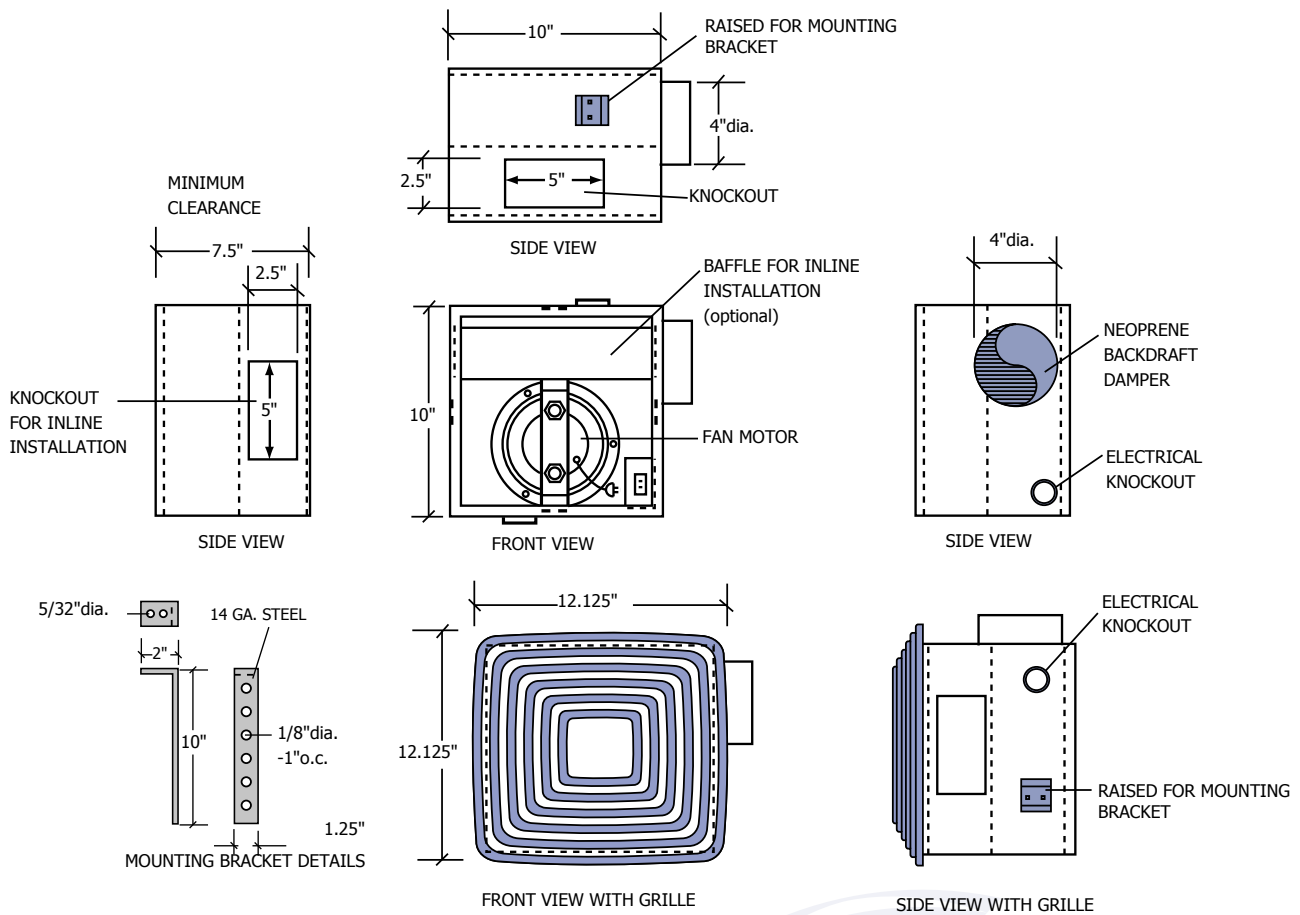

**HVI CERTIFIED RATINGS**

MODEL	SONES	CFM @ 0.10" S.P.
QB-80	1.5	60



**FAN DATA**

MODEL	MOTOR 120 VAC 60 Hz		CUBIC FEET PER MINUTE								
	RPM	AMPS	S.P.	0.00	0.05	0.10	0.15	0.20	0.25	0.30	0.35
QB-80	1020	0.40	CFM	70	66	65	62	57	53	45	20

RPM (Revolution Per Minute) shown is nominal and performance is based on actual speed of test. Unit was tested with inlet grille, backdraft damper and outlet duct.

Contractor:	QB-80			
Architect:	Job:	DatW	Supersedes	Drawing NO.
Engineer:	Date Submitted:			

**Reversomatic Manufacturing Ltd.**