

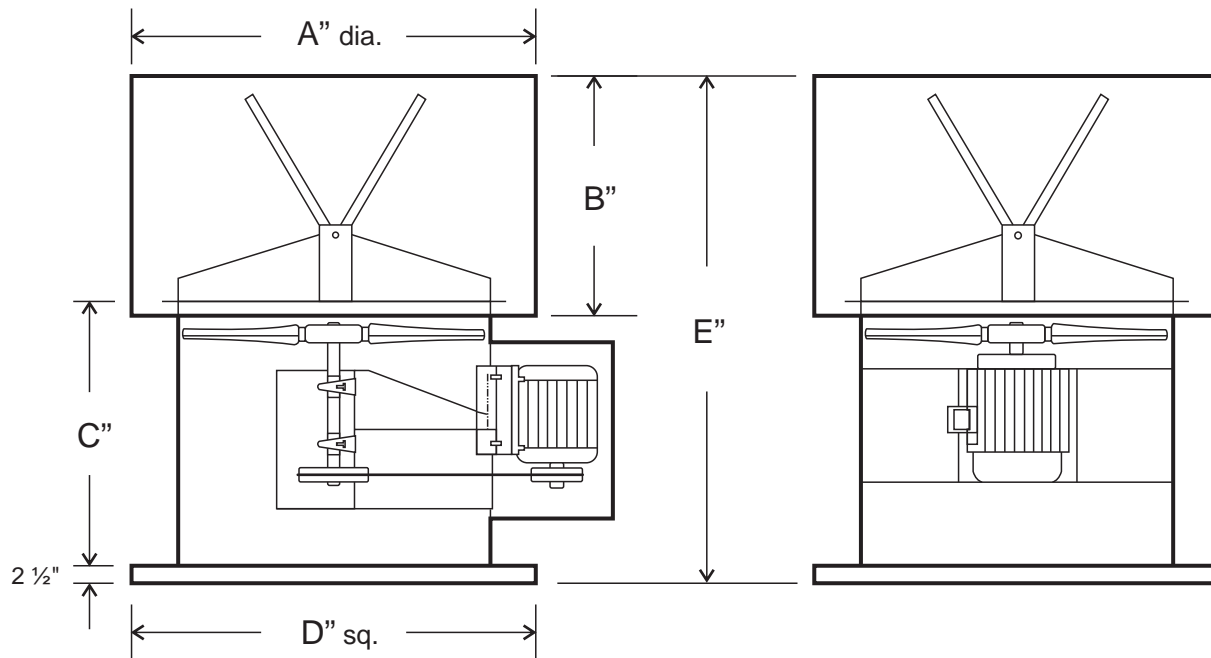

## Airfoil Tubeaxial Up Blast Fans

**UBD  
(BELT DRIVEN)**

**UDD  
(DIRECT DRIVE)**



FAN SIZE	A	B	C		D	E	
12	21	13	20		18	36	
15	24	15	20		21	36	
18	27	16	20		24	37	
21	30	18	23		27	42	
24	33	19	23		30	43	
30	39	24	23	30*	36	48	55*
36	45	27	28	30*	42	56	58*
40	49	29	28	30*	46	58	60*
42	51	30	28	30*	48	59	61*
48	57	34	30*	44**	57 1/2	67	79**

**MAINTENANCE:** Tubeaxial fans should be cleaned as necessary to remove accumulated dust, dirt and other foreign matter which may collect on the blades or interior surfaces belt drive, belt(s) should be inspected and tension adjusted. Check belt(s) for proper alignment .  
On all belt driven models fan bearings are factory lubricated for extended service.  
External relubrication fan bearing fittings are standard with belt drive models.  
Pillow-block ball bearings should be lubricated annually or more frequently, depending upon conditions and operating cycle.  
For lubrication of electric motor, see instructions supplied by motor manufacturer.

**NOTE:** \* For motors 7 1/2 HP or larger, dimension 'C' = 30"  
\*\* For motors larger than 25 HP, dimension 'C' = 44"

# PERFORMANCE DATA OF TUBEAXIAL FANS

<b>DIRECT DRIVE</b>		150/5 BA: BLADE ANGLE				150/10 BA: BLADE ANGLE							
RPM	CFM	0" SP		1/8" SP		1/4" SP		3/8" SP		1/2" SP		3/4" SP	
		BA	HP	BA	HP	BA	HP	BA	HP	BA	HP	BA	HP
<b>UDD 12"</b>													
1170	800	24	0.02	31	0.04	36	0.09						
	1000	33	0.04	37	0.10								
1740	800	13	0.03	13	0.04	17	0.06	22	0.09	23	0.13		
	1000	18	0.05	19	0.06	23	0.09	29	0.13	28	0.18		
	1200	24	0.07	26	0.09	30	0.13	31	0.21	34	0.26		
	1400	30	0.11	33	0.14	34	0.25	37	0.31				
	1600	38	0.19	38	0.32								
<b>UDD 15"</b>													
1170	1400	21	0.05	25	0.08	27	0.13						
	1600	25	0.07	30	0.11	31	0.17						
	1800	30	0.09	39	0.16	34	0.23						
	2000	32	0.19	33	0.22								
	2200	34	0.26										
1740	1400	11	0.09	11	0.09	13	0.12	16	0.15	19	0.19	21	0.33
	1600	14	0.11	14	0.11	16	0.14	19	0.18	23	0.24	24	0.38
	1800	17	0.12	17	0.14	19	0.17	23	0.23	27	0.30	26	0.45
	2000	19	0.15	20	0.17	23	0.22	26	0.28	31	0.37	29	0.52
	2200	23	0.19	24	0.21	26	0.28	30	0.34	28	0.46	33	0.64
	2400	26	0.24	27	0.27	30	0.34	36	0.46	30	0.54	36	0.78
	2600	29	0.29	31	0.33	35	0.44	31	0.56	32	0.65		
	2800	32	0.36	34	0.42	32	0.60	33	0.68	34	0.78		
	3000	32	0.65	32	0.65	33	0.72	34	0.82				
	3200	33	0.79	33	0.79	34	0.87						

<b>DIRECT DRIVE</b>		150/5 BA: BLADE ANGLE				150/10 BA: BLADE ANGLE									
RPM	CFM	0" SP		1/8" SP		1/4" SP		3/8" SP		1/2" SP		3/4" SP		1" SP	
		BA	HP	BA	HP	BA	HP	BA	HP	BA	HP	BA	HP	BA	HP
<b>UDD 18"</b>															
864	1000	10	0.02	14	0.03	19	0.07								
	1200	11	0.02	17	0.04	22	0.09								
	1400	14	0.03	21	0.05	25	0.10								
	1600	17	0.04	24	0.07	29	0.14								
	1800	20	0.05	29	0.08	33	0.17								
	2000	24	0.06	36	0.11	38	0.21								
1170	1600	11	0.06	13	0.07	18	0.11	19	0.17	24	0.25				
	1800	13	0.07	15	0.08	20	0.13	21	0.20	26	0.27				
	2000	15	0.08	17	0.10	23	0.16	23	0.23	29	0.32				
	2400	21	0.12	23	0.14	30	0.22	29	0.36	36	0.47				
	2800	25	0.16	29	0.20	30	0.42	34	0.44						
	3200	30	0.22	37	0.30	34	0.45								
	3600	39	0.33	36	0.46										
	4000	39	0.54												
1740	2400	10	0.19	12	0.20	12	0.24	14	0.28	17	0.34	24	0.55	22	0.70
	2800	14	0.24	14	0.24	15	0.29	18	0.35	20	0.42	31	0.73	24	0.83
	3200	17	0.30	17	0.31	19	0.37	21	0.44	28	0.66	23	0.76	28	1.08
	3600	20	0.36	21	0.39	23	0.46	25	0.55	29	0.66	28	1.09	33	1.36
	4000	24	0.47	24	0.49	26	0.58	29	0.68	34	0.83	32	1.39	37	1.62
	4400	27	0.59	28	0.62	31	0.72	35	0.87	32	1.41	34	1.48		
	4800	31	0.73	32	0.79	36	0.95	33	1.39	34	1.46	39	1.79		
	5200	36	0.95	39	1.06	34	1.38	36	1.53	38	1.71				
	5600	36	1.46	36	1.48	38	1.68	39	1.86						



DIRECT DRIVE		150/5 BA: BLADE ANGLE				150/10 BA: BLADE ANGLE									
RPM	CFM	0" SP		1/8" SP		1/4" SP		3/8" SP		1/2" SP		3/4" SP		1" SP	
		BA	HP	BA	HP	BA	HP	BA	HP	BA	HP	BA	HP	BA	HP
<b>UDD 21"</b>															
864	1800	11	0.04	15	0.07	18	0.13								
	2000	13	0.04	17	0.07	19	0.15								
	2400	16	0.06	21	0.10	23	0.18								
	2800	20	0.08	26	0.13	27	0.23								
	3200	24	0.11	31	0.18	31	0.29								
	3400	27	0.13	35	0.21	34	0.33								
	3600	29	0.16	30	0.25	37	0.38								
	3800	32	0.18	32	0.29										
	4000	32	0.25	34	0.33										
	4200	34	0.29	37	0.38										
4400	36	0.33	39	0.43											
4600	38	0.38													
1170	2400	11	0.09	12	0.12	15	0.17	20	0.23	19	0.35				
	2800	13	0.12	14	0.14	18	0.20	24	0.30	21	0.41				
	3200	16	0.14	17	0.18	21	0.25	28	0.38	24	0.48				
	3600	19	0.19	21	0.23	25	0.32	34	0.47	27	0.56				
	4000	22	0.23	24	0.28	29	0.39	26	0.54	30	0.67				
	4400	25	0.29	27	0.35	33	0.49	29	0.63	34	0.81				
	4800	28	0.37	31	0.44	30	0.62	33	0.77	39	1.02				
	5200	32	0.47	37	0.58	33	0.76	37	0.95						
	5600	38	0.61	34	0.77	37	0.93								
	6000	36	0.83	37	0.93										
6400	39	1.01													
1740	3600	11	0.30	11	0.31	12	0.38	13	0.45	14	0.52	19	0.70	18	1.06
	4000	12	0.36	12	0.37	13	0.43	14	0.51	16	0.60	21	0.80	19	1.19
	4400	14	0.42	14	0.43	14	0.49	17	0.59	19	0.68	23	0.95	21	1.33
	4800	16	0.48	16	0.49	17	0.58	19	0.68	21	0.79	26	1.10	23	1.47
	5200	18	0.58	18	0.59	19	0.68	21	0.79	23	0.92	29	1.27	24	1.62
	5600	20	0.67	20	0.69	22	0.80	23	0.92	25	1.06	32	1.48	26	1.83
	6000	22	0.79	22	0.81	24	0.92	26	1.06	28	1.23	38	3.11	29	2.04
	6400	24	0.92	24	0.93	26	1.07	28	1.23	31	1.42	28	1.91	31	2.30
	6800	27	1.06	27	1.10	28	1.24	31	1.42	34	1.66	30	2.11	33	2.62
	7200	29	1.27	29	1.29	31	1.46	34	1.68	29	1.99	32	2.43	36	3.03
	7600	31	1.47	32	1.51	34	1.72	31	2.09	32	2.30	34	2.76	39	3.51
	8000	34	1.72	35	1.77	32	2.21	33	2.41	34	2.63	37	3.19		
	8400	39	2.08	34	2.35	34	2.55	35	2.77	37	3.01				
	8800	35	2.63	35	2.63	37	2.89	38	3.14	39	3.41				
9200	38	3.01	38	3.01	39	3.25									



# PERFORMANCE DATA OF TUBEAXIAL FANS

DIRECT DRIVE																				
RPM	CFM	0" SP		1/8" SP		1/4" SP		3/8" SP		1/2" SP		3/4" SP		1" SP		1-1/2" SP		2" SP		
		BA	HP	BA	HP	BA	HP	BA	HP	BA	HP	BA	HP	BA	HP	BA	HP	BA	HP	
<b>UDD 24"</b>		<b>150/5 BA: BLADE ANGLE</b>						<b>150/10 BA: BLADE ANGLE</b>												
864	2800	12	0.07	15	0.10	23	0.19	22	0.31											
	3200	14	0.09	18	0.13	28	0.24	25	0.35											
	3600	18	0.11	21	0.16	34	0.30	28	0.42											
	4000	20	0.14	24	0.20	24	0.34	31	0.49											
	4400	23	0.17	28	0.25	28	0.40	35	0.57											
	4800	26	0.21	32	0.30	31	0.47													
	5200	29	0.26	37	0.38	34	0.55													
	5600	33	0.33	32	0.48	38	0.66													
	6000	39	0.43	35	0.57															
	6400	35	0.54	38	0.67															
1170	3400	10	0.15	11	0.18	14	0.23	18	0.31	23	0.47	24	0.81							
	3800	12	0.18	13	0.20	16	0.27	19	0.36	28	0.58									
	4200	14	0.21	15	0.23	18	0.32	22	0.43	19	0.63	27	0.99							
	4600	16	0.24	17	0.28	20	0.37	24	0.50	21	0.71	29	1.10							
	5000	18	0.29	19	0.33	22	0.44	27	0.60	23	0.80	32	1.24							
	5400	20	0.34	21	0.39	24	0.51	31	0.70	25	0.89									
	5800	22	0.41	23	0.46	27	0.60	34	0.81	28	1.01									
	6200	24	0.47	26	0.54	30	0.70	27	0.96	30	1.14									
	6600	26	0.54	28	0.63	33	0.80	29	1.07	32	1.28									
	7000	29	0.64	31	0.73	39	0.98	32	1.22	34	1.43									
1740	7400	32	0.76	34	0.84	31	1.16	34	1.37	38	1.64									
	7700	34	0.88	38	0.98	33	1.28	36	1.51											
	8200	33	1.17	34	1.27	36	1.50	39	1.75											
	8600	35	1.32	36	1.44	38	1.67													
	9000	37	1.50	38	1.61															
	5000	10	0.50	10	0.50	11	0.56	12	0.64	13	0.72	17	0.94	20	1.24	19	2.20			
	6000	13	0.65	13	0.65	14	0.70	15	0.80	17	0.92	19	1.18	24	1.63	23	2.64			
	7000	17	0.82	17	0.82	17	0.92	19	1.05	20	1.20	23	1.57	31	2.25	27	3.21			
	8000	20	1.12	20	1.13	21	1.24	22	1.40	24	1.58	28	2.07	24	2.72	31	3.91			
	9000	23	1.47	23	1.47	24	1.62	26	1.83	28	2.07	34	2.65	28	3.35	35	4.72			
10000	27	1.87	27	1.89	29	2.11	31	2.35	33	2.62	29	3.49	32	4.09						
11000	32	2.48	32	2.50	34	2.71	37	3.08	31	3.67	33	4.31	36	5.01						
12000	38	3.46	39	3.47	33	3.92	34	4.27	35	4.60	37	5.28								
13000	36	4.54	36	4.54	37	4.85	38	5.20	39	5.56										
<b>UDD 30"</b>		<b>150/5 BA: BLADE ANGLE</b>						<b>150/10 BA: BLADE ANGLE</b>												
864	4000	10	0.09	12	0.15	17	0.24	16	0.42											
	5000	13	0.14	15	0.20	20	0.33	18	0.51	24	0.72									
	6000	16	0.18	18	0.27	24	0.43	22	0.63	28	0.90									
	7000	19	0.26	22	0.37	29	0.56	25	0.78	32	1.10									
	8000	23	0.35	26	0.48	26	0.73	29	0.96											
	9000	26	0.46	31	0.62	29	0.90	33	0.12											
	10000	31	0.64	39	0.93	33	1.15													
	11000	37	0.86	33	1.10	37	1.46													
	12000	35	1.16	37	1.38															
	13000	39	1.47																	
1170	5400	10	0.21	10	0.28	12	0.39	15	0.50	18	0.66	17	1.13							
	6000	11	0.27	12	0.33	14	0.44	16	0.58	19	0.75	18	1.24							
	7000	14	0.38	14	0.41	16	0.55	19	0.73	22	0.93	20	1.41							
	8000	16	0.44	16	0.52	19	0.69	21	0.89	25	1.12	23	1.66							
	9000	18	0.57	19	0.64	21	0.86	24	1.09	29	1.38	25	1.94							
	10000	21	0.69	22	0.81	24	1.06	28	1.32	24	1.67	28	2.27							
	11000	23	0.90	24	1.02	27	1.27	32	1.67	27	1.96	31	2.65							
	12000	25	1.08	27	1.24	31	1.54	27	1.99	29	2.28	34	3.18							
	13000	29	1.40	30	1.51	36	2.05	29	2.32	32	2.72									
	14000	33	1.76	37	2.14	31	2.40	33	2.79	35	3.24									
1740	15000	37	2.22	32	2.45	34	2.85	36	3.31	39	3.90									
	16000	34	2.82	35	2.90	37	3.37	39	3.91											
	17000	37	3.28	38	3.42	39	3.93													
	8000	10	0.70	10	0.70	10	0.88	11	1.05	12	1.22	14	1.53	17	1.94	15	3.33			
	10000	13	1.14	13	1.14	13	1.23	14	1.42	14	1.61	17	2.08	20	2.62	18	4.13	23	5.71	
	11000	14	1.41	14	1.41	14	1.43	15	1.65	16	1.89	19	2.41	22	3.02	19	4.47	25	6.29	
	12000	16	1.48	16	1.48	16	1.67	17	1.92	18	2.19	21	2.78	24	3.44	22	5.01	27	7.10	
	13000	18	1.77	18	1.77	18	1.94	19	2.21	20	2.52	23	3.20	26	3.94	23	5.58	29	7.81	
	14000	19	2.09	19	2.09	20	2.22	21	2.58	22	2.94	24	3.66	28	4.48	25	6.20	31	8.65	
	15000	21	2.34	21	2.34	22	2.63	23	3.01	24	3.40	27	4.14	33	5.59	27	6.91	33	9.75	
16000	23	2.80	23	2.80	23	3.09	24	3.50	26	3.87	29	4.64	25	5.86	28	7.64				
17000	24	3.31	24	3.31	25	3.56	27	3.96	28	4.34	33	5.56	27	6.53	30	8.48				
18000	26	3.64	26	3.64	27	4.06	28	4.45	30	4.89	39	6.36	28	7.24	33	9.63				
19000	28	4.36	28	4.36	29	4.63	31	5.15	34	5.93	29	7.08	30	8.06	35	10.93				
20000	31	5.14	31	5.14	32	5.49	34	6.19	38	7.28	30	7.94	32	9.13						
21000	33	5.94	33	5.94	38	6.53	30	7.30	31	7.83	32	8.97	34	10.27						
22000	36	6.84	36	6.84	32	7.67	32	8.23	33	8.81	34	10.06	37	11.60						
23000	33	8.41	33	8.41	33	8.61	34	9.22	35	9.86	37	11.29	39	13.00						
24000	35	9.25	35	9.25	35	9.63	36	10.30	37	11.01	39	12.57								



**DIRECT DRIVE**

RPM	CFM	0" SP		1/8" SP		1/4" SP		3/8" SP		1/2" SP		3/4" SP		1" SP		1-1/2" SP		2" SP		2 1/2" SP		3" SP		
		BA	HP	BA	HP	BA	HP	BA	HP	BA	HP	BA	HP	BA	HP	BA	HP	BA	HP	BA	HP	BA	HP	
<b>UDD 36"</b>		<b>150/5 BA: BLADE ANGLE</b>										<b>150/10 BA: BLADE ANGLE</b>												
864	7000	10	0.35	11	0.40	13	0.51	16	0.66	20	0.95	19	1.50											
	8000	12	0.41	12	0.46	14	0.56	18	0.80	23	1.11	21	1.75											
	10000	15	0.50	16	0.58	19	0.83	22	1.11	28	1.50	26	2.28											
	12000	19	0.74	20	0.85	23	1.10	27	1.46	24	1.96	29	2.84											
	14000	24	1.00	25	1.11	28	1.50	30	2.06	28	2.47	34	3.62											
	16000	28	1.42	30	1.60	33	2.12	33	2.67	32	3.10													
	18000	31	1.99	33	2.29	33	2.90	34	3.30	37	4.00													
	20000	34	2.82	35	3.13	37	3.63	39	4.30															
22000	38	3.87	39	4.03																				
1170	9500	10	0.88	10	0.91	11	1.03	12	1.16	13	1.31	17	1.83	24	2.77									
	10000	10	0.94	10	0.96	12	1.08	13	1.21	14	1.36	18	1.96	24	2.90									
	12000	13	1.14	13	1.14	14	1.25	15	1.43	17	1.76	21	2.51	28	3.72									
	14000	16	1.33	16	1.36	17	1.61	19	1.95	20	2.32	24	3.07	22	4.26									
	16000	19	1.78	19	1.79	20	2.11	22	2.44	23	2.81	28	3.82	25	5.05									
	18000	22	2.20	22	2.24	24	2.55	25	2.95	27	3.49	33	4.98	28	6.01									
	20000	26	2.87	26	2.87	27	3.27	29	3.82	31	4.48	28	6.00	30	7.07									
	22000	29	3.67	29	3.72	30	4.27	32	4.97	34	5.77	31	7.10	33	8.38									
	24000	31	4.69	31	4.85	33	5.54	34	6.34	32	7.16	34	8.29	38	10.39									
	26000	33	6.12	33	6.23	34	7.04	34	7.71	35	8.34	38	10.12											
28000	36	8.07	36	8.07	37	8.61	37	9.31	38	10.12														
30000	39	9.81	39	9.81	39	10.33																		
1740	14100	10	2.89	10	2.89	10	2.95	10	3.11	11	3.29	12	3.69	13	4.12	16	5.34	19	7.60	16	9.79	19	12.04	
	16000	12	3.36	12	3.36	12	3.38	12	3.53	12	3.70	13	4.09	14	4.51	18	6.39	22	8.85	18	11.15	21	13.81	
	18000	13	3.78	13	3.78	13	3.78	13	3.88	14	4.06	15	4.49	16	5.45	19	7.64	24	10.15	20	12.72	23	15.88	
	20000	15	4.01	15	4.01	15	4.05	15	4.29	16	4.66	17	5.59	19	6.66	22	8.85	27	11.89	22	14.68	25	17.95	
	22000	17	4.94	17	4.94	17	4.97	18	5.30	18	5.75	19	6.82	21	7.82	24	10.05	30	13.66	24	16.51	27	20.45	
	24000	19	5.98	19	5.98	19	5.98	20	6.34	20	6.82	22	7.82	23	8.87	27	11.65	24	15.76	26	18.64	29	20.60	
	26000	21	6.76	21	6.76	21	6.88	22	7.29	23	7.77	24	8.82	25	10.11	29	13.49	26	17.69	28	20.81	31	25.51	
	28000	24	8.03	24	8.03	24	8.04	24	8.34	25	8.82	26	10.31	28	11.96	33	16.27	28	19.80	30	23.10	34	28.71	
	30000	26	9.65	26	9.65	26	9.63	26	10.03	27	10.69	28	12.30	30	14.15	37	20.02	29	22.01	32	26.17			
	32000	28	11.39	28	11.39	28	11.45	29	12.01	29	12.77	31	14.68	32	16.88	30	21.41	32	24.08	34	29.16			
	34000	30	13.12	30	13.12	30	13.50	31	14.37	31	15.33	32	17.47	34	19.87	32	23.95	34	27.59	39	35.13			
	36000	31	15.88	31	15.88	31	16.20	32	17.18	32	18.24	34	20.56	32	23.29	34	26.51	37	31.66					
38000	33	19.01	33	19.01	33	19.18	33	20.30	34	21.46	33	24.12	34	25.65	36	30.00	39	36.47						

<b>UDD 40"</b>		<b>250/7 BA: BLADE ANGLE</b>										<b>250/14 BA: BLADE ANGLE</b>												
864	8000	10	0.29	11	0.39	13	0.53	15	0.69	19	0.96	17	1.70											
	10000	13	0.43	13	0.49	15	0.66	18	0.93	22	1.24	20	2.03											
	12000	16	0.53	16	0.63	18	0.88	21	1.19	26	1.59	23	2.47											
	14000	18	0.71	19	0.81	21	1.13	24	1.49	32	2.23	26	3.03											
	16000	21	0.86	22	1.05	24	1.44	30	2.08	25	2.58	29	3.67											
	18000	24	1.19	25	1.40	29	1.99	35	2.69	28	3.21	33	4.46											
	20000	28	1.62	29	1.91	34	2.64	29	3.45	31	3.91	39	5.81											
	22000	32	2.22	34	2.62	31	3.65	33	4.08	34	4.59													
	24000	37	2.90	39	3.47	34	4.20	36	4.84	38	5.68													
	1170	12000	11	0.87	11	0.90	12	1.11	13	1.31	14	1.51	17	2.14	22	3.02	20	5.06						
14000	13	1.13	13	1.13	14	1.30	15	1.52	16	1.85	19	2.61	24	3.53	22	5.92								
16000	15	1.28	15	1.32	16	1.57	17	1.89	19	2.26	22	3.11	30	4.82	24	6.69								
18000	18	1.59	18	1.60	18	1.90	19	2.28	21	2.72	24	3.65	34	5.84	27	7.99								
20000	19	1.93	19	1.93	20	2.27	22	2.75	23	3.25	28	4.71	24	6.01	29	9.14								
22000	22	2.22	22	2.30	23	2.79	24	3.32	26	4.00	32	5.79	26	7.01	32	10.58								
24000	24	2.82	24	2.84	25	3.42	27	4.18	29	5.03	37	7.24	28	8.18										
26000	26	3.48	27	3.61	28	4.34	30	5.22	33	6.20	29	8.14	31	9.48										
28000	29	4.54	29	4.60	31	5.47	34	6.50	37	7.67	31	9.40	33	10.79										
30000	33	5.64	33	5.81	35	6.85	38	8.03	32	9.34	33	10.57												
32000	36	6.81	36	7.16	39	8.42	33	9.76	34	10.37														
1740	16000	10	2.37	10	2.37	10	2.51	10	2.82	10	3.11	12	3.69	13	4.26	15	5.51	18	7.68	14	11.25	17	13.54	
	18000	11	2.91	11	2.91	11	2.92	12	3.23	12	3.54	13	4.14	14	4.73	17	6.43	20	8.75	16	12.67	18	14.96	
	20000	13	3.48	13	3.48	13	3.48	13	3.66	13	3.98	14	4.59	15	5.31	18	7.40	22	9.89	18	13.95	19	16.23	
	22000	14	4.08	14	4.08	14	4.08	14	4.10	14	4.41	15	5.18	17	6.16	19	8.42	23	11.04	19	15.14	21	17.99	
	24000	16	4.27	16	4.27	16	4.34	16	4.66	16	5.05	17	5.98	18	7.05	21	9.49	25	12.34	20	16.49	23	19.76	
	26000	17	4.96	17	4.96	17	4.96	17	5.33	17	5.77	18	6.81	19	7.97	23	10.65	28	15.16	22	18.21	24	21.54	
	28000	18	5.69	18																				



# PERFORMANCE DATA OF TUBEAXIAL FANS

BELT DRIVE 150 mm HUB DIA. 5 BLADES 25° BLADE ANGLE										
MOTOR H.P.	Max. Input Power Watts	FAN RPM	0" SP CFM	1/8" SP CFM	1/4" SP CFM	3/8" SP CFM	1/2" SP CFM	3/4" SP CFM	1" SP CFM	1-1/2 SP CFM
<b>UBD-12"</b>										
0.25 HP	353	2371	1294	1251	1167	1076	986	766		
0.33 HP	471	2601	1429	1382	1303	1224	1142	953	662	
0.50 HP	707	2988	1632	1592	1518	1446	1370	1205	946	
0.75 HP	1059	3420	1870	1820	1760	1690	1620	1460	1200	460
1.00 HP	1413	3765	2057	2006	1949	1879	1812	1657	1384	566
<b>UBD-15"</b>										
0.50 HP	631	1860	2258	2070	1850	1610	1215	250		
0.75 HP	1032	2192	2661	2500	2348	2145	1930	810	353	
1.00 HP	1268	2348	2850	2710	2560	2390	2200	1610	590	
1.50 HP	1894	2685	3260	3200	3000	2876	2760	2364	1190	432
2.00 HP	2528	2955	3587	3390	3280	3190	3080	2790	2300	850
<b>UBD-18"</b>										
0.75 HP	864	1951	3613	3493	3256	3021	2769	2230		
1.00 HP	1153	2148	3978	3857	3641	3421	3197	2699	1995	
1.50 HP	1730	2459	4558	4445	4245	4038	3831	3379	2690	878
2.00 HP	2307	2706	5018	4895	4713	4519	4313	3880	3174	1213
3.00 HP	3460	3097	5741	5599	5439	5251	5059	4632	3875	1600
<b>UBD-21"</b>										
0.75 HP	800	1580	4606	4422	4064	3698	3320	2340		
1.00 HP	1068	1739	5066	4895	4570	4231	3878	3099		
1.50 HP	1602	1991	5797	5642	5348	5044	4726	4045	3065	
2.00 HP	2136	2191	6384	6227	5952	5665	5371	4729	3763	1199
3.00 HP	3204	2508	7305	7125	6896	6619	6350	5736	4721	1854
<b>UBD-24"</b>										
1.00 HP	987	1478	7996	7636	7124	6624	5997	4505		
1.50 HP	1480	1691	9150	8839	8391	7977	7458	6424	4924	
2.00 HP	1973	1861	10071	9786	9375	9017	8524	7655	6528	
3.00 HP	2960	2132	11479	11227	10915	10603	10187	9459	8524	3742
5.00 HP	4933	2528	13664	13318	13059	12840	12494	11836	11098	5548
<b>UBD-27"</b>										
1.00 HP	931	1365	9738	9096	8264	7495	6516	5148		
1.50 HP	1396	1561	11170	10585	9848	9193	8424	6648		
2.00 HP	1861	1718	12285	11799	11071	10491	9788	8409	7171	
3.00 HP	2792	1969	14047	13654	12962	12451	11821	10743	9345	4409
5.00 HP	4654	2334	16650	16278	15690	15272	14704	13745	12590	5940

BELT DRIVE			150 mm HUB DIA. 5 BLADES 25° BLADE ANGLE									
MOTOR HP	Max. Input Power Watts	FAN RPM	0" SP CFM	1/8" SP CFM	1/4" SP CFM	3/8" SP CFM	1/2" SP CFM	3/4" SP CFM	1" SP CFM	1-1/2" SP CFM	2" SP CFM	2-1/2" SP CFM
<b>UBD-30"</b>												
1.00 HP	883	1148	11479	10556	9404	8366	7035					
1.50 HP	1324	1313	13191	12332	11305	10408	9389	6872				
2.00 HP	1765	1445	14500	13812	12767	11965	11052	9163				
3.00 HP	2648	1655	16614	16081	15008	14299	13455	12027	10165			
5.00 HP	4412	1963	19635	19238	18322	17704	16914	15654	14082	6333		
7.50 HP	6619	2247	22455	22000	21440	20817	19990	18803	17440	8583		
<b>UBD-33"</b>												
1.00 HP	841	990	13221	12016	10545	8467	7554					
1.50 HP	1262	1133	15211	14078	12762	10969	10355	7096				
2.00 HP	1682	1246	16714	15825	14462	12859	12316	9917				
3.00 HP	2523	1428	19182	18508	17055	15637	15088	13310	10986			
5.00 HP	4205	1693	22621	22198	20953	19718	19124	17562	15574	6725		
7.50 HP	6308	1938	25870	25385	24519	23185	22602	21095	19288	9114		
<b>UBD-36"</b>												
2.00 HP	1760	1045	17769	16390	15240	13964	12311	8783				
3.00 HP	2640	1196	20278	19219	18073	16873	15531	13292	6733			
5.00 HP	4400	1418	24093	23316	22176	21140	19793	18135	11399			
7.50 HP	6600	1627	27506	26731	26731	24922	23581	22122	14465			
10.0 HP	8800	1787	30317	29462	29462	27928	26517	25256	16798			

**NOTE:** Performance shown is for installation type A; Free Inlet, Free Outlet. Performance ratings do not include the effects of appurtenances in the airstream. Power (BHP) includes drive losses. The sound ratings shown are loudness values in fan sones at 1.5 m (5 ft.) in a hemispherical free field calculated per AMCA International Standard 301. Values shown are for: Installation A: Free inlet hemispherical sone levels.

### SONES AT 0.00" STATIC PRESSURE

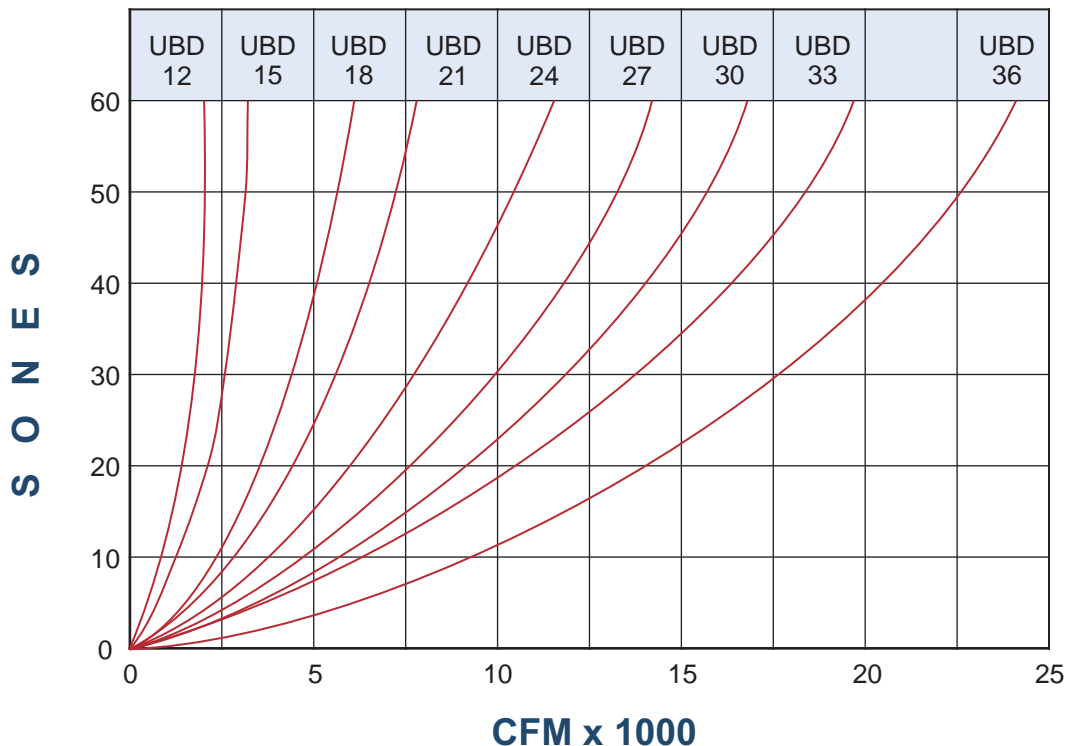

<b>BELT DRIVE</b>											
MOTOR HP	FAN RPM	0" SP CFM	1/8" SP CFM	1/4" SP CFM	3/8" SP CFM	1/2" SP CFM	3/4" SP CFM	1" SP CFM	1-1/2" SP CFM	2" SP CFM	2-1/2" SP CFM
<b>UBD-40"</b>		<b>250 mm HUB DIA. 7 BLADES 25° BLADE ANGLE</b>									
2.00 HP	949	20100	19600	18200	16600	14700					
3.00 HP	1086	23100	22600	21700	20300	18900	15400				
5.00 HP	1288	27300	27300	26500	25500	24400	21900	19000			
7.50 HP	1475	31300	31300	30800	30000	29100	27200	25000	19400		
10.0 HP	1623	34500	34500	34200	33500	32800	31100	29200	24800	18300	
<b>UBD-42"</b>		<b>250 mm HUB DIA. 7 BLADES 25° BLADE ANGLE</b>									
2.00 HP	848	19800	19080	17370	15300	12780					
3.00 HP	972	22680	22230	20790	19170	17370	11790				
5.00 HP	1153	26910	26730	25650	24480	23040	19890	15570			
7.50 HP	1319	30780	30780	29970	28980	27900	25380	22590			
10.0 HP	1454	33930	33930	33390	32490	31590	29430	27090			
15.0 HP	1662	38790	38790	38610	37980	37170	35460	33570	29250		
20.0 HP	1832	42750	42750	42660	42120	41490	40050	38430	34830	30600	25110
25.0 HP	1974	46080	46080	45990	45630	45090	43830	42390	39150	35640	31410
<b>UBD-48"</b>		<b>380 mm HUB DIA. 14 BLADES 25° BLADE ANGLE</b>									
2.00 HP	771	22000	21200	19300	17000	14200					
3.00 HP	884	25200	24700	23100	21300	19300	13100				
5.00 HP	1048	29900	29700	28500	27200	25600	22100	17300			
7.50 HP	1199	34200	34200	33300	32200	31000	28200	25100			
10.0 HP	1322	37700	37700	37100	36100	35100	32700	30100			
15.0 HP	1513	43100	43100	42900	42200	41300	39400	37300	32500		
20.0 HP	1665	47500	47500	47400	46800	46100	44500	42700	38700	34000	27900
25.0 HP	1794	51200	51200	51100	50700	50100	48700	47100	43500	39600	34900

**NOTE:** Heavy duty blades are available for 20 to 50 HP & 40,000 to 70,000 CFM fans depend on operating conditions. Contact factory for selection & more information.





**REVERSOMATIC**  
MANUFACTURING LIMITED

## **INSTALLATION & MAINTENANCE GUIDE**

General Instructions

**REGULAR MAINTENANCE / LUBRICATION OF THIS UNIT IS REQUIRED TO MAINTAIN THE MANUFACTURER'S WARRANTY.**

**FOR MOTORS LARGER THAN 7 ½ HP, AN ELECTRONIC "SOFT START" CONTROL IS RECOMMENDED FOR LONGER BELT LIFE.**

### **C A U T I O N**

IT IS STRONGLY RECOMMENDED THAT BEFORE STARTING UP THE FAN THE FOLLOWING INSPECTIONS ARE PERFORMED.

- 1. FAN BELT (IF USED) TIGHTNESS AND ALIGNMENT.**
- 2. FAN BLADE CENTERING AND ROTATION.**
- 3. FAN BLADE MOUNTING BOLT TIGHTNESS.**
- 4. MOTOR MOUNTING PLATE BOLT TIGHTNESS.**
- 5. BEARING LUBRICATION.**

### **WARNINGS AND SAFETY INSTRUCTIONS**

1. Do not operate the fan excess of maximum limit.
2. Do not permit any object to enter the fan inlets or outlets; provide a screen covering.
3. Do not operate the fan without adequate guards over rotating parts; provide drive belt, coupling and shaft guards.
4. Provide a disconnect switch with a padlock to prevent fan switch use during maintenance.
5. Locate a disconnect switch at the fan for use of personnel working on the fan.
6. Provide vibration limiting switches to detect sudden changes in the operation of the fan, especially when operating a fan under high temperatures or in an extremely corrosive atmosphere such as fly ash.
7. Lubricate and service bearings regularly. see lubrication schedule.

**Reversomatic Manufacturing Ltd.**

790 Rowntree Dairy Road, Woodbridge, ON, Canada L4L 5V3 • Tel: 905-851-6701 • Fax: 905-851-8376  
www.reversomatic.com • info@reversomatic.com

# INSTALLATION & MAINTENANCE GUIDE

## Performance Problems:

**CFM too low** - These are some common sources of this problem:

**Fan** - forward curved impeller installed backwards, fan running backwards, cutoff missing or improperly installed, impeller not centered with inlet collars, fan speed too slow.

**System** - more resistant to flow than expected, dampers or registers closed, leaks in supply ducts, insulating duct liner loose, clogged filters or coils.

**Fan Inlets** - leaks around fan inlets, elbows near the inlet, cabinet walls too close. Inlet obstructions cause more restrictive systems but do not cause increased negative pressure readings near the fan inlets. Fan speed may be increased to counteract the effect of restricted fan inlet, but check the maximum RPM for the wheel construction before increasing the speed.

**Fan Outlet** - most centrifugal fans are used in ducted systems and have been tested with a length of straight duct at the fan outlet, If there is no straight duct at the fan outlet, decreased fan performance will result. If it is not practical to install a straight section of duct at the fan outlet, the fan speed may be increased to overcome this pressure loss. Other sources affecting fan outlet may be sharp elbow nearby, improperly designed turning vanes or other obstructions near the outlet.

**Noise** - may be caused by:

- Impeller hitting the inlet of the fan or cutoff plate, loose impeller.
- Drives can cause noise if sheaves are not tight on the shaft, belts are too loose or too tight, wrong belt cross section, or mis-matched belts, also worn belts, oily belts or mis-aligned sheaves.
- If couplings are used they may be source of noise by being unbalanced, misaligned, loose or dry of lubricant.
- Bad bearings are a common source of noise when defective, dry of lubricant, loose on the bearing support, loose on the shaft, seals mis-aligned, dirty lubricant, fretting corrosion between inner race and shaft, etc. See separate section on bearing care.
- There can be an electrical source of noise such as AC hum in motor or relay, starting relay chatter, noisy motor bearings, single phasing a 3 phase motor, etc.
- A bent or undersized shaft may be a noise source. **IF MORE THAN TWO BEARINGS ARE ON THE SAME SHAFT, THEY MUST BE CAREFULLY ALIGNED.**
- There may be other noise sources such as obstruction in high velocity air stream causing rattle or pure tone whistle, fan operating at undesirable design point, causing pulsation, cracks or holes in duct work, or whistles in fan housing.

## LUBRICATION

### RELUBRICATION SCHEDULE (MONTHS)\* Ball Bearing Pillow Blocks

SHAFT DIAMETER	Operating Speed (RPM)									
	500	1000	1500	2000	2500	3000	3500	4000	4500	5000
5/8" thru 1"	6	6	6	6	4	4	4	4	2	2
1 1/8" thru 1 1/2"	6	6	6	4	4	4	2	2	2	1
1 5/8" thru 1 15/16"	6	6	6	4	4	2	2	1	1	-
2" thru 2 1/2"	6	6	4	4	2	1	1	-	-	-
2 11/16" thru 3 3/16"	6	4	2	2	1	1	1/2	-	-	-

\*Suggested initial greasing interval - relubricate while running, if safety permits, until some purging occurs at seals. Adjust lubrication frequency depending on condition of purged grease. Hours of operation, temperature, and surrounding conditions will affect the relubrication frequency required.

- Lubricate with a high quality NLGI No. 2 or No.3 multi purpose ball bearing grease having rust inhibitors and anti-oxidant additives.

**Some grease having these properties are:**

- Shell - *Alvania EP No.2*
- Mobil - *Mobilux Ep2*
- Texaco - *Molytex No.2*
- Gulf - *Gulfcrown No. 2*
- American - *Amolith No. 2*

- Lubricate bearings prior to extended shutdown or storage and rotate shaft monthly to avoid corrosion.

### Spherical Roller Bearings - Solid Pillow Blocks

SHAFT DIAMETER	Operating Speed (RPM)									
	500	1000	1500	2000	2200	2700	3000	3500	4000	4500
3/4" thru 1"	6	6	6	4	4	4	2	2	1	1
1 1/8" thru 1 1/4"	6	6	4	4	2	2	1	1	1	1
1 7/16" thru 1 1/2"	6	4	4	2	2	1	1	1	1	1/2
1 5/8" thru 1 3/4"	6	4	2	2	1	1	1	1	1/2	-
1" 15/16" thru 2"	6	4	2	1	1	1	1	1/2	-	-
2 3/16" thru 2 1/4"	6	4	2	1	1	1	1/2	-	-	-
2 7/16" thru 2 1/2"	4	2	1	1	1	1/2	-	-	-	-
2 11/16" thru 3"	4	2	1	1	1/2	-	-	-	-	-
3 3/16" thru 3 1/2"	4	2	1	1/2	-	-	-	-	-	-

- Lubricate with a multi-purpose roller bearing NLGI grade 2 grease having rust inhibitors, anti-oxidant additives, and a minimum oil viscosity of 500 SSU at 100°F. Some additives.

**Some grease having these properties are:**

- American - *Rykon No.2*
- Mobil - *Mobilgrease 28*
- Texaco - *Molytex Ep2 grease*

- Lubricate bearings prior to extended shutdown or storage and rotate shaft monthly to avoid corrosion.

## RECOMMENDED 'SKF' GREASES FOR 'SKF' BEARINGS

*Fixed Pillow Block* - LGMT2 Fans running below 80°C (176°F)

*Split Pillow Block* - LGMT3 Fans running below 80°C (176°F)

**Fans Running Above 80°C thru 150°C - LGHT3**

## TROUBLESHOOTING LIST

- IMPELLER** . . . . . a. Loose on shaft  
b. Unbalance
- DRIVE** . . . . . a. Sheave not tight on shaft (motor or fan)  
b. Belts hitting belt tube or belt guard  
c. Belts too loose. Adjust for belt stretching after 48 hours of operation.  
d. Belts too tight  
e. Belts wrong cross-section  
f. Belts not "Matched" in length on multi-belt drive  
g. Variable pitch sheaves not adjusted so each groove has same pitch diameter (multi-belt drive)  
h. Misaligned sheaves  
i. Belts worn  
j. Motor, Motor base or fan not securely anchored  
k. Belts oily or dirty  
l. Improper drive selection  
m. loose key  
n. Excessive start-stop cycles
- COUPLING** . . . . . a. Coupling unbalanced, misaligned, loose or may need lubricant  
b. Loose key
- BEARING** . . . . . a. Defective bearing  
b. Needs lubrication  
c. Loose on bearing support  
d. Loose on shaft  
e. Seals misaligned  
f. Foreign material inside bearing  
g. Worn bearing  
h. Fretting corrosion between inner race and shaft  
i. Bearing not sitting on flat surface  
j. Excessive belt tension
- SHAFT** . . . . . a. Bent  
b. Undersized
- MOTOR** . . . . . a. Noisy motor bearings  
b. Single phasing a three phase motor  
c. Low voltage
- LOOSE FASTENERS** . . . . . a. Impeller set screws  
b. Bearing set screws  
c. Drive component set screws  
d. Fan mounting bolts  
e. Bearing bolts  
f. Motor bolts