

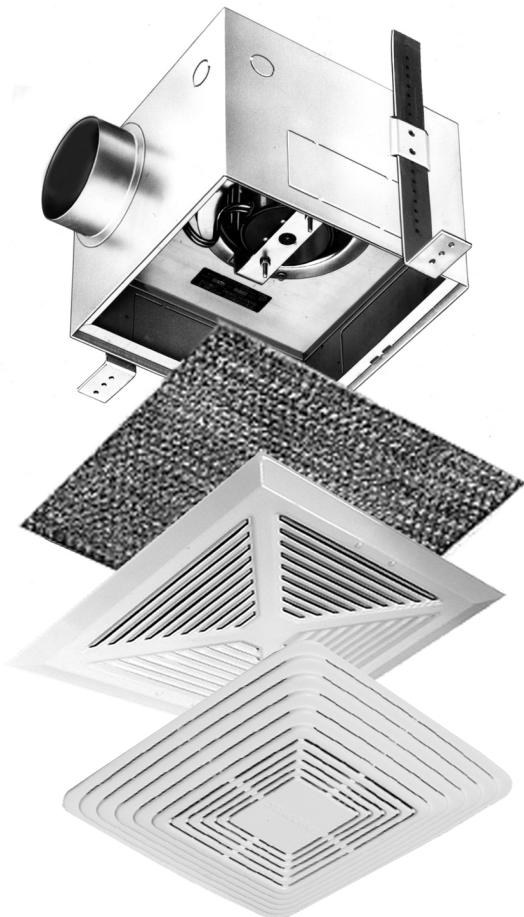

**XL SERIES
KITCHEN/BATHROOM EXHAUST FAN**

The QK-100 fan is specially designed to provide powerful and effective ventilation in the kitchen. However, it can also be used for bathroom exhaust by eliminating the aluminum mesh washable grease filter. It is also available with mounting brackets for easy installation. The QK-100 fan is constructed of corrosion resistant heavy gauge satin coat steel.



IMPORTANT:
Aluminum Mesh
Grease Filter is optional &
must be installed for kitchen use.

White Aluminum
Louvered Grille

High Impact Styrene
Grille (Bathroom use only)

QK-100 FAN DATA

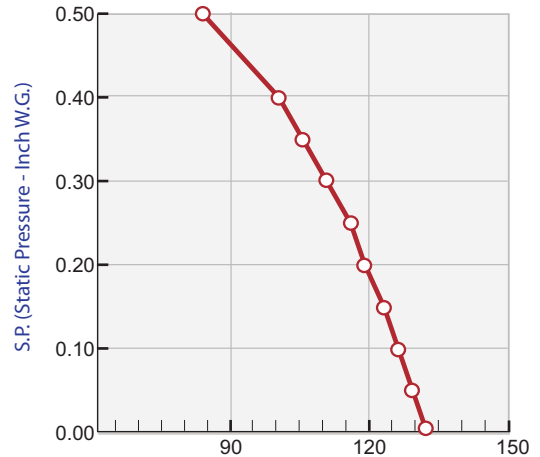

Air Flow (CFM - Cubic Feet Per Minute)

ACCESSORIES

Standard:

- Mounting brackets
- White aluminum louvered grille

Optional:

- Variable speed control
- Aluminum backdraft damper
- Aluminum mesh grease filter
- Baffle
- Inline transition
- Balance box



QK-100(QB-150 US model)

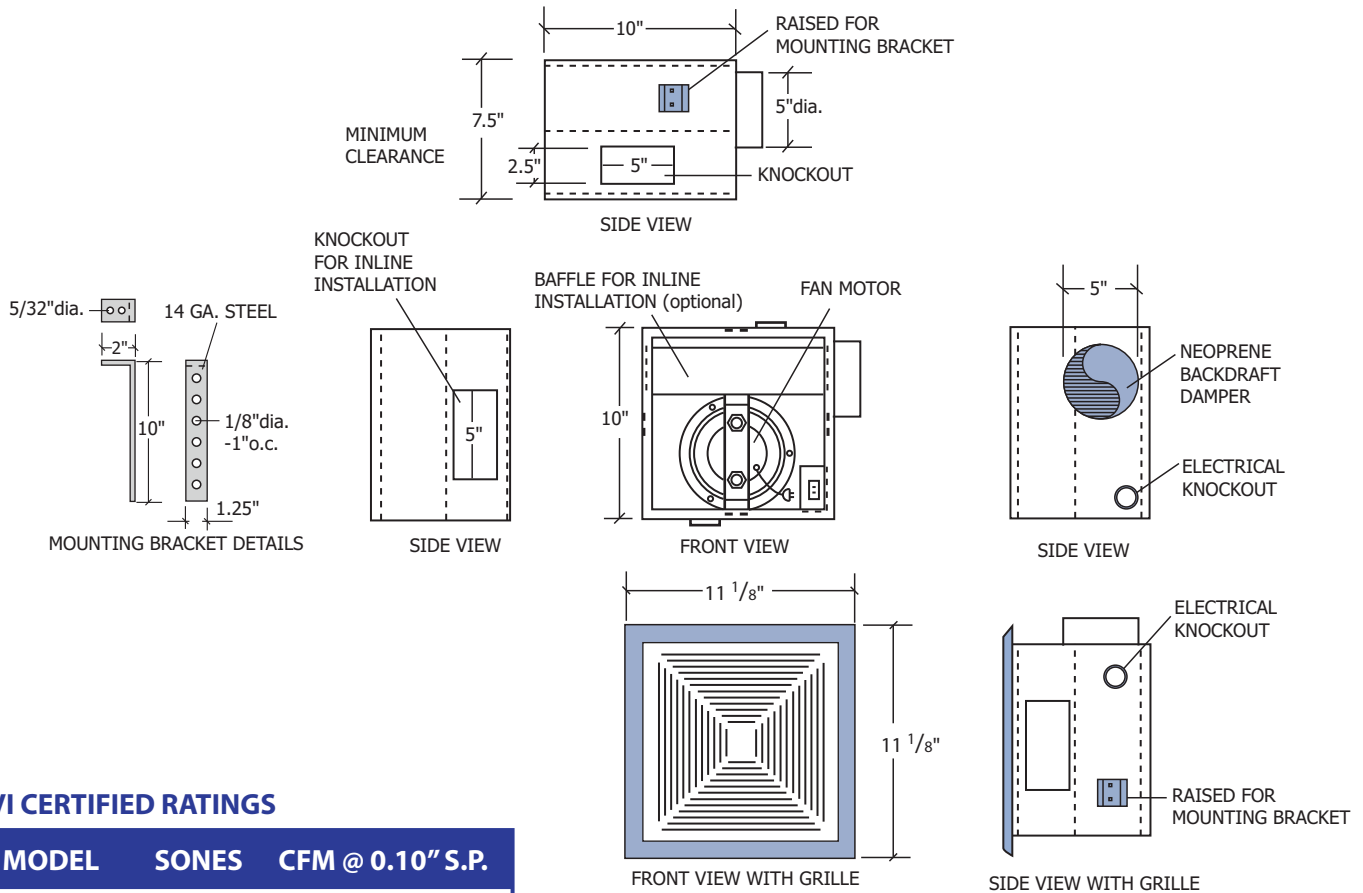

HVI CERTIFIED RATINGS

MODEL	SONES	CFM @ 0.10" S.P.
QK-100	4.5	130

FAN DATA

MODEL	MOTOR 120 VAC 60 Hz		CUBIC FEET PER MINUTE										
	RPM	AMPS	S.P.	0.00	0.05	0.10	0.15	0.20	0.25	0.30	0.35	0.40	0.50
QK-100	1050	0.90	CFM	129	126	123	120	116	113	108	103	98	82

RPM (Revolution Per Minute) shown is nominal and performance is based on actual speed of test. Unit was tested with inlet grille, backdraft damper and outlet duct.

SOUND RATING

OCTAVE BAND		1	2	3	4	5	6	7	8
CENTER FREQUENCY Hz		63	125	250	500	1000	2000	4000	8000
STATIC PRESSURE INCH W.G.	0.00	63.6	57.2	58.3	59.0	56.5	49.5	47.7	51.6
	0.29	63.7	56.0	56.3	57.1	54.5	47.5	45.7	50.6
	0.60	64.0	58.0	55.4	55.2	51.8	49.1	46.9	49.1

The sound power level ratings shown are in decibels, referred to 10^{-12} watts calculated per AMCA Standard 301. Values shown are for inlet Law sound power levels for installation Type B: free inlet, ducted outlet. Ratings do not include the effects of duct end correction.

Contractor:	QK-100 (QB-150 US model)		
Architect:	Job:	Data	Supersedes
Engineer:	Date Submitted:		Drawing NO.

Reversomatic Manufacturing Ltd.

790 Rowntree Dairy Road, Woodbridge, ON Canada L4L 5V3 • Tel: 905-851-6701 • Fax: 905-851-8376
 www.reversomatic.com • info@reversomatic.com