



ACCESSORIES: LEAK-PROOF WALL BOXES WITH MAGNET

PATENT PENDING

Maintains Constant Pressure inside the Condo/House and keeps the damper close when the system is not operating.

Test Standard:

Cyclic Static Test ASTM E547-00

Tested @ 400 Pa

Grills standard: aluminum stucco.

Grills option: smooth finish.

SINGLE WALL BOX

MODEL: SWBLM-8

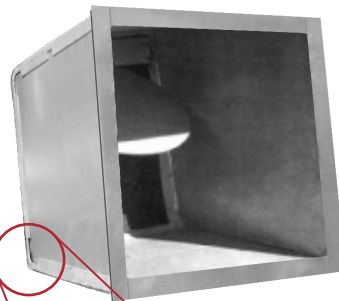

Extruded Aluminum Grille
(optional for all sizes)

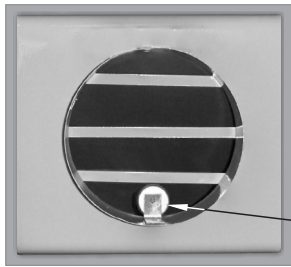

Back View

Magnet

- Factory set to prevent 0.05" to 0.10" W.C.
back-draft created inside the house/condo

Leak Proof Seamless
Flanged Wrap Construction

DOUBLE WALL BOX

MODEL: DWBLM-8 c/w Stamped Aluminum Grille

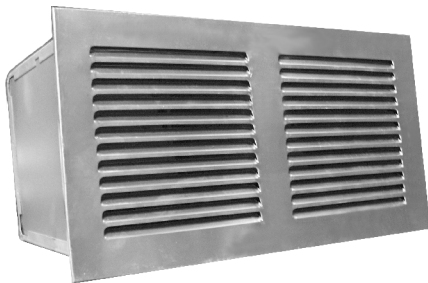

TRIPLE WALL BOX

MODELS: TWBLM-8 c/w Stamped Aluminum Grille

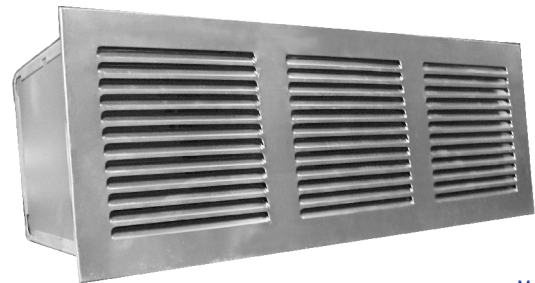

March, 2012

ACCESSORIES: LEAK-PROOF WALL BOXES WITH MAGNET

PATENT PENDING

SINGLE WALL BOX MODEL: SWBLM-8 c/w Stamped Aluminum Grille

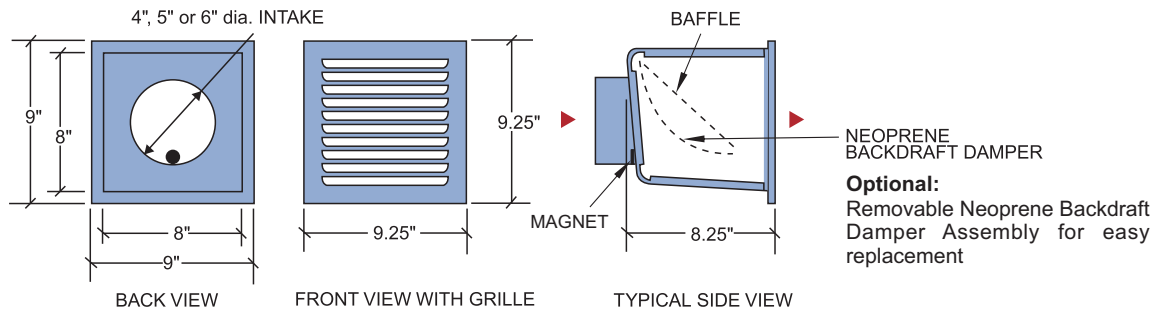

DOUBLE WALL BOX MODEL: DWBLM-8 c/w Stamped Aluminum Grille

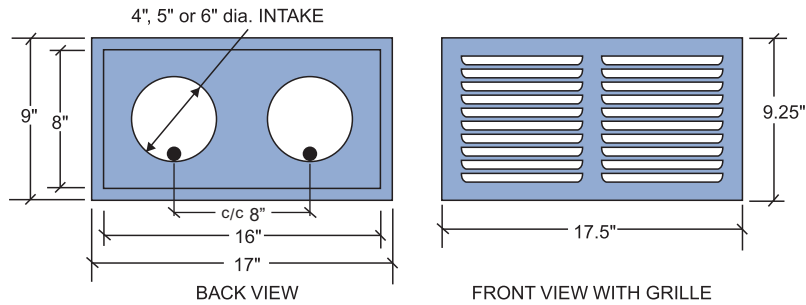

TRIPLE WALL BOX MODEL: TWBLM-8 c/w Stamped Aluminum Grille

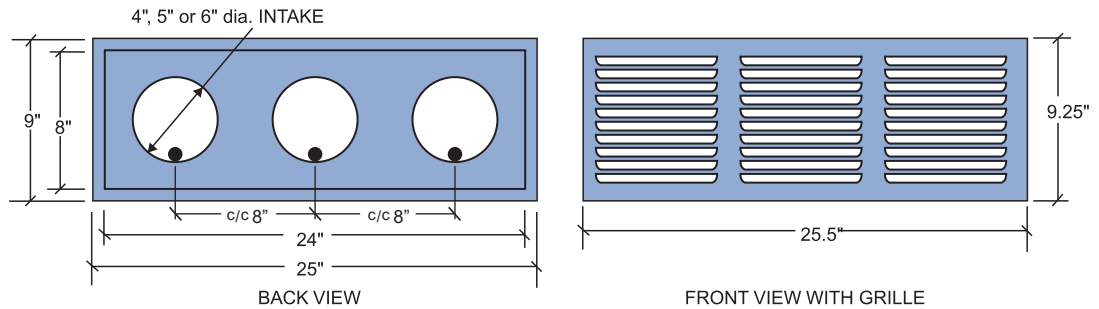

EXTRUDED ALUMINUM GRILLES

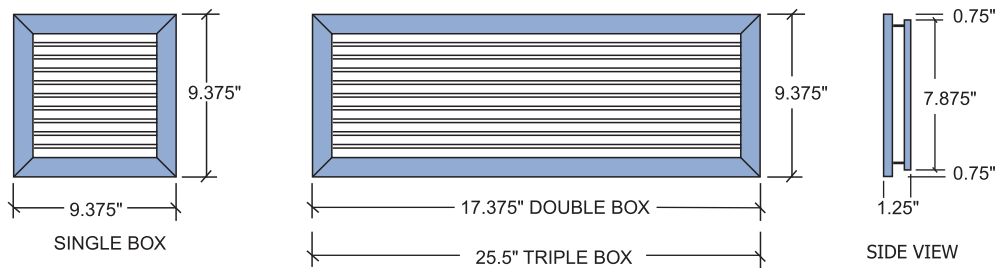

| | | | | |
|-------------|-----------------|-----------------------------------|------------|-------------|
| Contractor: | | Leak-proof Wall Boxes with Magnet | | |
| Architect: | Job: | Date | Supersedes | Drawing No. |
| Engineer: | Date Submitted: | | | |

Reversomatic Manufacturing Ltd.

790 Rowntree Dairy Road, Woodbridge, ON Canada L4L 5V3 • Tel: 905-851-6701 • Fax: 905-851-8376
www.reversomatic.com • info@reversomatic.com