



XL SERIES BATHROOM EXHAUST FANS

The B-60 and QB-60 fans are specially designed for bathrooms in apartments which require low noise levels. They have been manufactured with a squirrel cage impeller for high performance and with slim housing allowing them to be installed between ceiling joists.



Plastic Backdraft Damper

High Impact Styrene Grille

Off White Aluminum Louvered Grille (optional)

FAN DATA

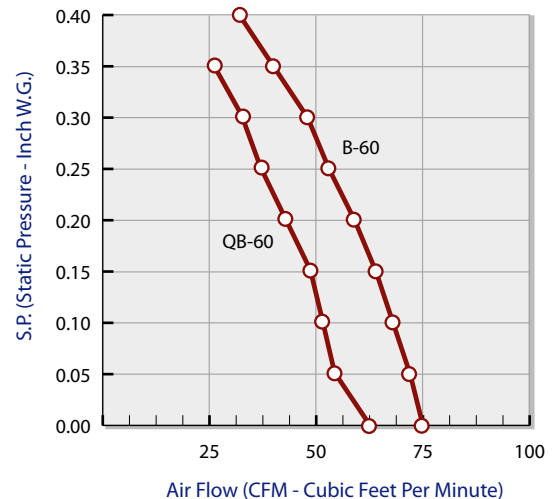

ACCESSORIES

Standard:

- Plastic backdraft damper or metal collar with neoprene damper
- Mounting bracket
- Plastic snap-in grille

Optional:

- Variable speed control
- Aluminum backdraft damper
- Off white aluminum grille



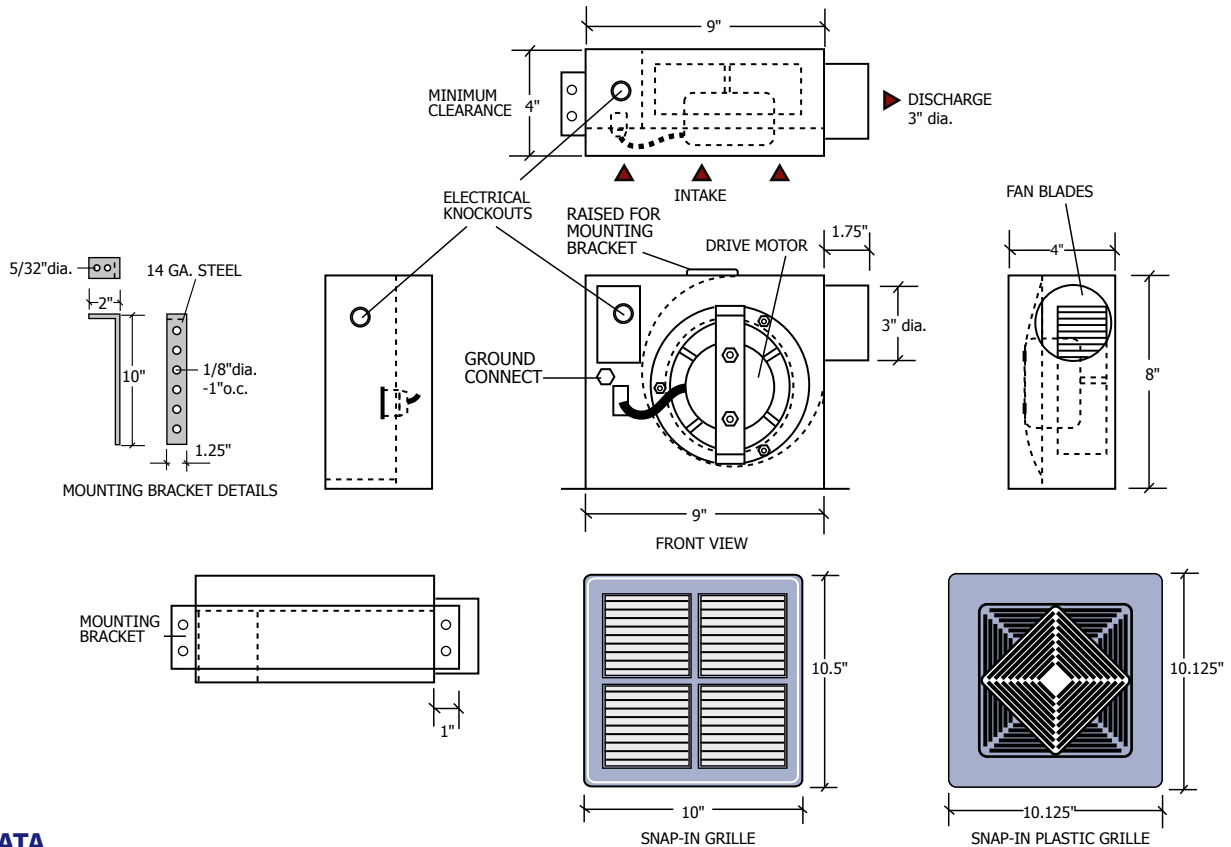

FAN DATA

MODEL	MOTOR 120 VAC 60 Hz			CUBIC FEET PER MINUTE									SONES
	RPM	AMPS	S.P.	0.00	0.05	0.10	0.15	0.20	0.25	0.30	0.35	0.40	
B-60	1550	0.60	CFM	75	72	68	64	59	53	48	40	32	2.5
QB-60	1250	0.35	CFM	59	54	52	49	46	40	34	27	-	2.0

RPM (Revolution Per Minute) shown is nominal and performance is based on actual speed of test. Unit was tested with inlet grille, backdraft damper and outlet duct.

SOUND RATING

OCTAVE BAND		1	2	3	4	5	6	7	8
CENTER FREQUENCY Hz		63	125	250	500	1000	2000	4000	8000
B-60 STATIC PRESSURE INCH W.G.	0.00	57	62	55	60	55	50	50	47
	0.22	58	62	52	56	53	50	45	44
	0.40	62	62	46	54	55	52	54	52
QB-60 STATIC PRESSURE INCH W.G.	0.00	59	50	50	56	51	45	42	39
	0.16	60	51	47	52	50	43	40	39
	0.33	59	50	47	52	48	41	37	38

The sound power level ratings shown are in decibels, referred to 10^{-12} watts calculated per AMCA Standard 301. Values shown are for inlet Lwi sound power levels for installation Type B: free inlet, ducted outlet. Ratings do not include the effects of duct end correction.

Contractor:	B-60, QB-60			
Architect:	Job:	Data	Supersedes	Drawing NO.
Engineer:	Date Submitted:			

Reversomatic Manufacturing Ltd.

790 Rowntree Dairy Road, Woodbridge, ON Canada L4L 5V3 • Tel: 905-851-6701 • Fax: 905-851-8376
 www.reversomatic.com • info@reversomatic.com