



**REVERSOMATIC**  
MANUFACTURING LIMITED

**FL-80, FLH-80**

## **FL-80 Fan/Lamp Bathroom Fan** **FLH-80 Fan/Lamp-Heater Bathroom Fan**

This bathroom fan is a single bulb combination fan and lamp or fan and heater lamp. It has the capability of exhausting air quietly and efficiently while enjoying 250 watt heat lamp.

### **FEATURES:**

- Quiet and Efficient Centrifugal Blower
- Plug-in Lifetime Lubricated Motor
- White epoxy Painted Aluminum Grille
- Sturdy Heavy Gauge Satin Coat Galvanized Construction
- Simplified Mounting System

\* 250W Light Bulb not Included



### **STANDARD FEATURES:**

- White aluminum grille
- Continuous duty life time lubricated motor with thermal protection
- Universal mounting brackets
- Neoprene vibration isolator
- Plug type disconnect

### **OPTIONAL FEATURES:**

- Speed controller
- Termination kit



**Reversomatic Manufacturing Ltd.**

790 Rowntree Dairy Road, Woodbridge, ON Canada L4L 5V3 • Tel: 905-851-6701 • Fax: 905-851-8376  
www.reversomatic.com • info@reversomatic.com

Model FLH80 - Fan-Light/Heater  
 Model FL80 - Fan-Light

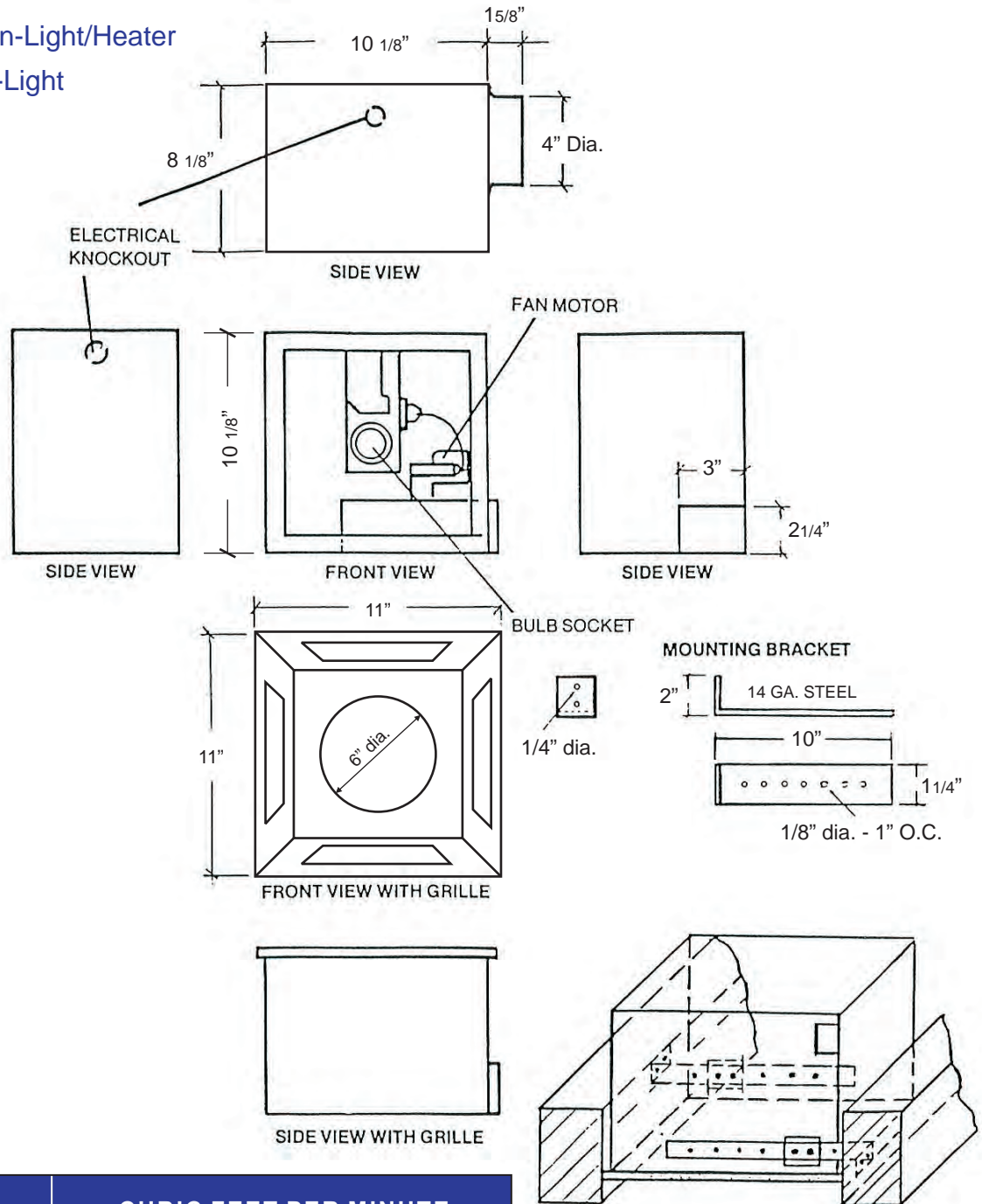

## FAN DATA

| MOTOR<br>120 VAC 60 Hz |      |      | CUBIC FEET PER MINUTE |     |      |      |      |      |      |
|------------------------|------|------|-----------------------|-----|------|------|------|------|------|
| RPM                    | AMPS | HP   | S.P.                  | 0.0 | 0.10 | 0.20 | 0.30 | 0.40 | 0.50 |
| 2200                   | 1.12 | 1/20 | CFM                   | 80  | 73   | 64   | 60   | 55   | 48   |

RPM (Revolution Per Minute) shown in nominal and performance is based on actual speed of test.

|             |                         |            |             |
|-------------|-------------------------|------------|-------------|
| Contractor: | <b>FL-80 and FLH-80</b> |            |             |
| Architect:  | Date                    | Supersedes | Drawing No. |
| Engineer:   |                         |            |             |

**Reversomatic Manufacturing Ltd.**

790 Rowntree Dairy Road, Woodbridge, ON Canada L4L 5V3 • Tel: 905-851-6701 • Fax: 905-851-8376  
 www.reversomatic.com • info@reversomatic.com