

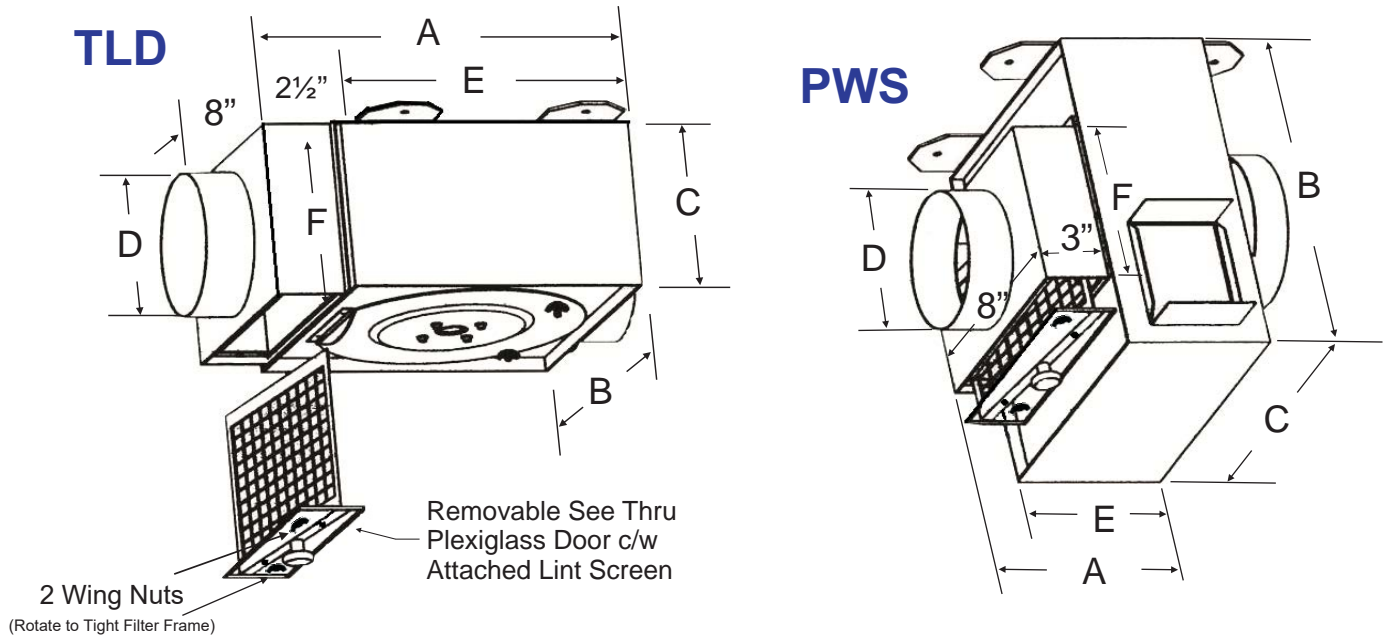

FANS WITH LINT TRAPS

Maintenance Instruction



DIMENSIONS:

MODEL	A	B	C	D (dia.)	E	F
TLD200L	13"	11"	6"	5"	10.5"	6"
TLD300L	14.5"	12"	8"	6"	12"	7"
PWS100L	6.5"	11"	9.5"	5"	4.5"	6"
PWS200L	6.5"	11"	9.5"	6"	4.5"	7"
PWS300L	7.5"	12.5"	11"	7"	5.5"	8"

NOTE:

- Lint trap must be cleaned monthly or as required by removing the two wing nuts and pulling the lint screen door down by the handle
- Clean fan assembly as required by removing two wing nuts from the main plate and motor will swing open
- Make sure the motor is unplugged to ensure there is no power to the motor
- Install fan combination lint trap where it is easily accessible for cleaning

Contractor:	<input type="checkbox"/> TLD - _____ <input type="checkbox"/> PWS - _____		
Architect:	Date	Supersedes	Drawing No.
Engineer:			

Reversomatic Manufacturing Ltd.

790 Rowntree Dairy Road, Woodbridge, ON Canada L4L 5V3 • Tel: 905-851-6701 • Fax: 905-851-8376
www.reversomatic.com • info@reversomatic.com