

TYPICAL INSTALLATION

CAUTION :TURN POWER OFF AT SERVICE PANEL BEFORE INSTALLATION.

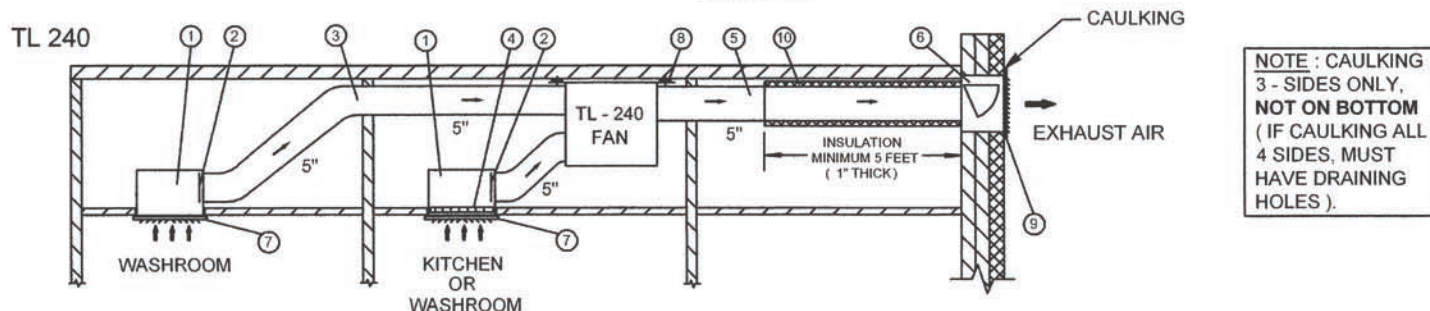
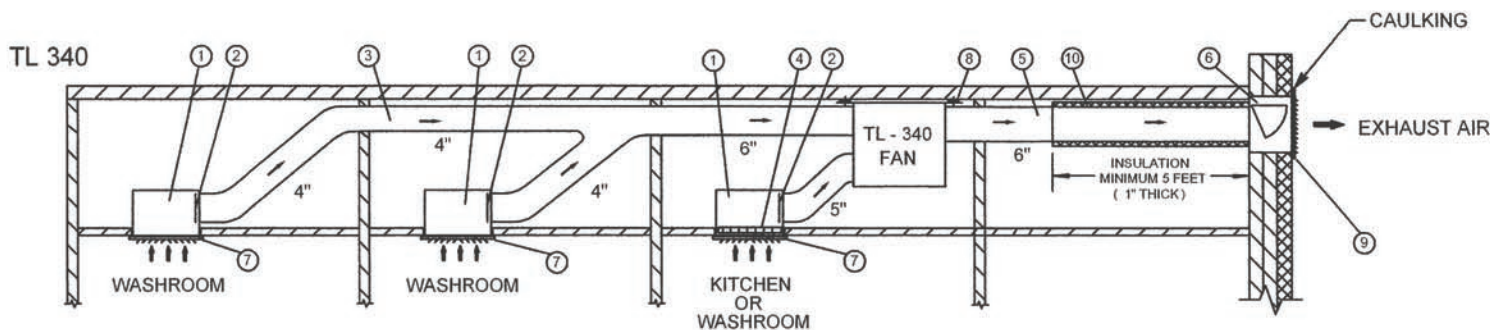

NOTE : CAULKING 3 - SIDES ONLY, NOT ON BOTTOM (IF CAULKING ALL 4 SIDES, MUST HAVE DRAINING HOLES).

NOTE : ALL DUCTING MUST COMPLY WITH LOCAL AND NATIONAL BUILDING CODES.

- | | |
|--|--|
| <ol style="list-style-type: none"> 1. BALANCE BOX 2. HAND ADJUSTED BALANCE DAMPER C/W NEOPRENE BACKDRAFT DAMPER 3. PIPE 4. GREASE FILTER (OPTIONAL - FOR KITCHEN USE ONLY) | <ol style="list-style-type: none"> 5. EXHAUST PIPE 6. WALL BOX C/W NEOPRENE BACKDRAFT DAMPER 7. GRILLE (FOR BALANCE BOX) 8. RUBBER MOUNT 9. GRILLE (FOR WALL BOX) 10. INSULATION |
|--|--|

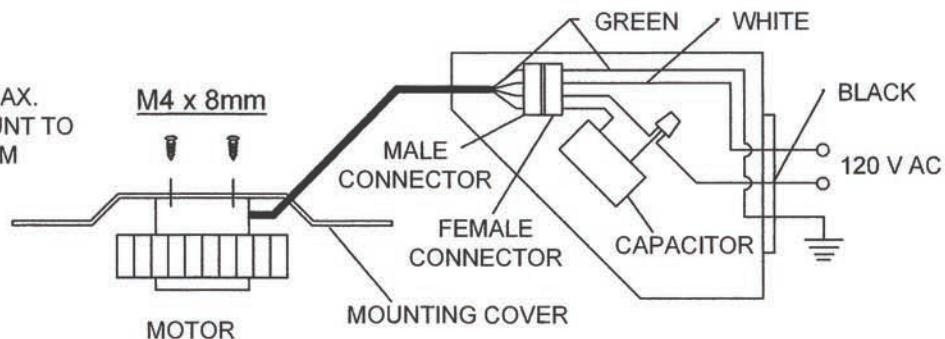
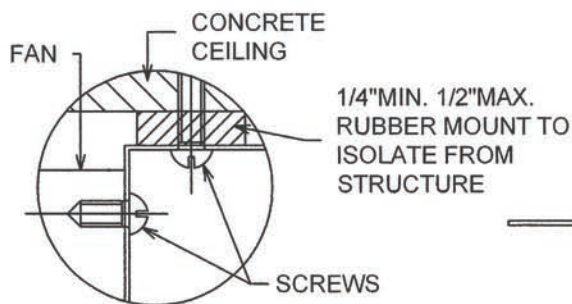

IMPORTANT INSTALLATION INSTRUCTIONS

1. Determine the best location for the fan.
2. Do not suspend fan from drywall or lathing channels, suspend from concrete ceiling or wood frame.
3. Avoid direct contact of fan with T bar or ceiling.
4. Connect fan with flexible canvas duct connector.
5. To install the grille, squeeze the two ends of each spring together and insert each into the slots on the wallbox. Push the grille up to the ceiling.
6. If the unit is being mounted in existing construction use the housing as a template to mark the necessary space on the ceiling to cut out.

MOTOR REPLACEMENT PROCEDURE

1. Disconnect power supply.
2. Remove electrical box cover.
3. Disconnect motor.
4. Remove motor from housing.
5. Remove mounting cover from motor.
6. Install mounting cover on replacement motor.
7. Install motor in housing.
8. Connect motor.
9. Replace electrical box cover.
10. Connect power supply.



REVERSOMATIC
MANUFACTURING LIMITED

790 ROWNTREE DAIRY ROAD WOODBRIDGE, ONTARIO L4L 5V3 CANADA
PHONE:- (905) 851-6701 FAX:- (905) 851-8376 E-mail:- info@reversomatic.com
www.reversomatic.com