



XL SERIES

THE PW-200 IS ESPECIALLY DESIGNED TO EXHAUST A COMBINATION OF WASH-ROOMS AND DRYER ROOM. IT HAS BEEN MANUFACTURED WITH A SPECIAL LINT-FREE IMPELLER*

PW-200 DRYER AND BATHROOM EXHAUST FAN

*MINIMUM CFM FOR VENTILATION AND/OR INTERCONNECTIONS OF DUCTS AND FANS COULD BE REGULATED BY YOUR LOCAL BY-LAWS. VERIFY ACCEPTANCE OF INSTALLATION WHEN NECESSARY



June, 2006

Reversomatic Manufacturing Ltd.

790 ROWNTREE DAIRY ROAD • WOODBRIDGE, ONTARIO, CANADA L4L 5V3 • PHONE (905) 851-6701 • FAX (905) 851-8376

www.reversomatic.com | EMAIL info@reversomatic.com

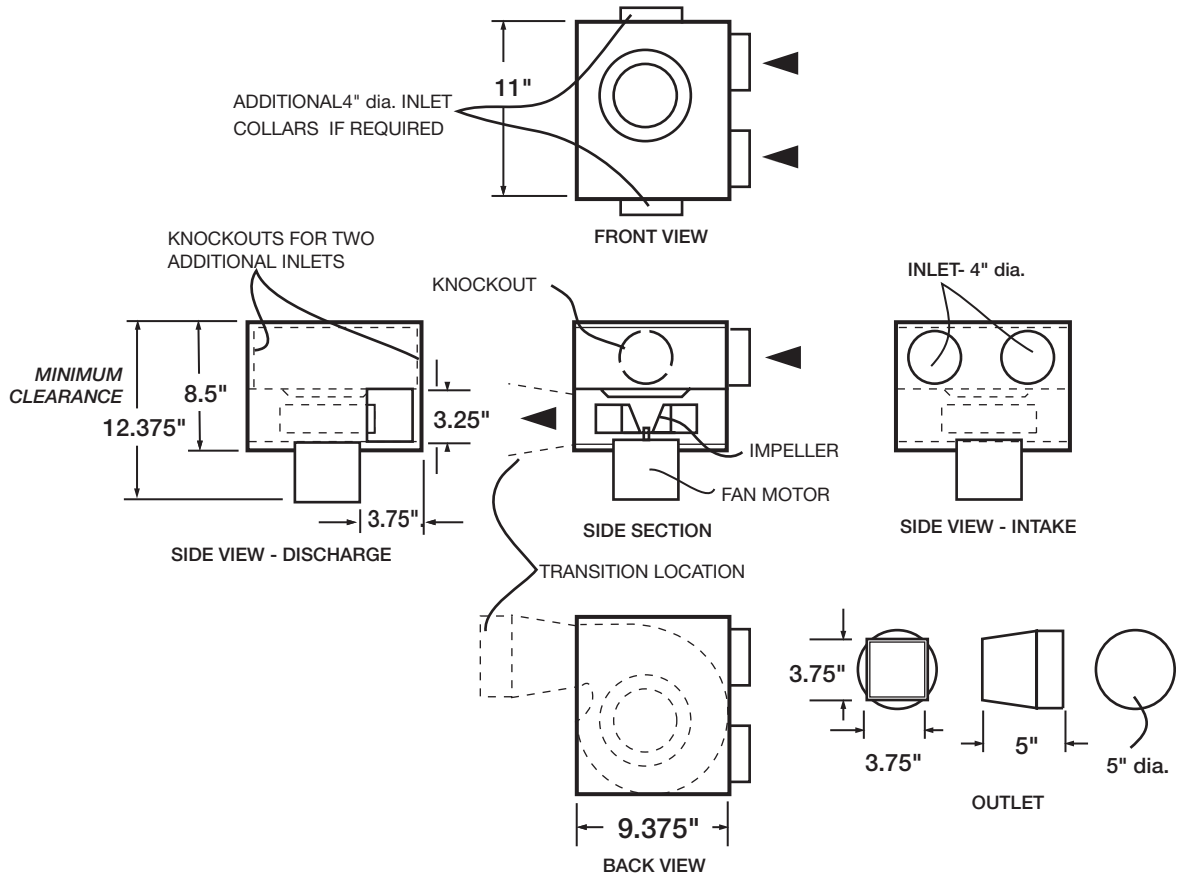

ACCESSORIES

- | | |
|-------------------|-----------------|
| STANDARD | OPTIONAL |
| DAMPER | BALANCE BOX |
| MOUNTING BRACKETS | TRANSITION |
| | LINT TRAP |
| | ACCESS DOOR |

FAN DATA

FAN MODEL	MOTOR 120 VAC 60 Hz			CUBIC FEET PER MINUTE								
	RPM	AMPS	HP	S.P.	.0	.05	.10	.20	.30	.40	.50	.55
PW-200	1670	1.15 to 1.33	1/35	CFM	170	162	154	136	118	98	68	52

RPM (Revolutions per minute) shown is nominal and performance is based on actual speed